

Application Manual

Real Time Clock Module

RX-4045SA/NB

Model	Product Number
RX-4045SA	Q41404551xxxx00
RX-4045NB	Q41404591xxxx00

EPSON TOYOCOM CORPORATION

NOTICE

- The material is subject to change without notice.
- Any part of this material may not be reproduced or duplicated in any form or any means without the written permission of Epson Toyocom.
- The information, applied circuit, program, usage etc., written in this material is just for reference. Epson Toyocom does not assume any liability for the occurrence of infringing any patent or copyright of a third party. This material does not authorize the licensing for any patent or intellectual copyrights.
- Any product described in this material may contain technology or the subject relating to strategic products under the control of the Foreign Exchange and Foreign Trade Law of Japan and may require an export licence from the Ministry of International Trade and industry or other approval from another government agency.
- You are requested not to use the products (and any technical information furnished, if any) for the development and/or manufacture of weapon of mass destruction or for other military purposes. You are also requested that you would not make the products available to any third party who may use the products for such prohibited purposes.
- These products are intended for general use in electronic equipment. When using them in specific applications that require extremely high reliability such as applications stated below, it is required to obtain the permission from Epson Toyocom in advance.
 - / Space equipment (artificial satellites, rockets, etc) / Transportation vehicles and related (automobiles, aircraft, trains, vessels, etc) / Medical instruments to sustain life / Submarine transmitters
 - / Power stations and related / Fire work equipment and security equipment / traffic control equipment
 - / and others requiring equivalent reliability.
- In this manual for Epson Tyocom, product code and marking will still remain as previously identified prior to the merger. Due to the on going strategy of gradual unification of part numbers, please review product code and marking as they will change during the course of the coming months. We apologize for the inconvenience, but we will eventually have a unified part numbering system for Epson Toyocom which will be user friendly.

Contents

1. Overview.....	1
2. Block Diagram	1
3. Description of Pins.....	2
3.1. Pin Layout.....	2
3.2. Pin Functions.....	2
4. Absolute Maximum Ratings	3
5. Recommended Operating Conditions	3
6. Frequency Characteristics	3
7. Electrical Characteristics.....	4
7.1. DC Electrical Characteristics	4
7.2. AC Electrical Characteristics	5
8. Functional descriptions	6
8.1. Overview of Functions	6
8.2. Description of Registers	7
8.3. Clock Precision Adjustment Function.....	14
8.4. Periodic Interrupt Function	16
8.5. Alarm W function	18
8.6. Alarm D function	20
8.7. /INT Output during Operation of Interrupt Function	21
8.8. The various detection Functions.....	22
8.9. Read/Write of Data.....	25
8.10. External Connection Example	30
9. External Dimensions / Marking Layout.....	31
9.1. External Dimensions.....	31
9.2. Marking Layout	31
10. Reference Data.....	32
11. Application notes	33

Miniature Serial Interface RTC Module

RX - 4045 SA / NB

- Features built-in 32.768-kHz quartz oscillator, frequency adjusted for high precision ($\pm 5 \times 10^{-6}$ when $T_a = +25^\circ\text{C}$)
- Serial interface in 4 lines form
- Includes time (H/M/S) and calendar (YR/MO/DATE/DAY) counter functions (BCD code)
- Select between 12-hr and 24-hr clock mode.
- Auto calculation of leap years until 2099
- Built-in high-precision clock precision control logic
- CPU interrupt generation function (cycle time range: 1 month to 0.5 seconds, includes interrupt flags and interrupt stop function)
- Dual alarm functions (Alarm_W: Day/Hour/Min, Alarm_D: Hour/Min)
- 32.768-kHz clock output (Nch open drain output)
- Oscillation stop detection function (used to determine presence of internal data)
- Power supply voltage monitoring function (with selectable detection threshold)
- Wide clock (retention) voltage range: 1.15 V to 5.5 V
- Wide interface voltage range: 1.7 V to 5.5 V
- Low current consumption: 0.48 μA / 3.0 V (Typ.)

1. Overview

This module is an four signal lines interface -compliant real-time clock which includes a 32.768-kHz quartz oscillator that has been adjusted for high precision. In addition to providing a function for generating six types of interrupts, a dual alarm function, an oscillation stop detection function (used to determine presence of valid internal data at power-on), and a power supply voltage monitoring function, this module includes a digital clock precision adjustment function that can be used to set various levels of precision. Since the internal oscillation circuit is driven at a constant voltage, 32.768-kHz clock output is stable and free of voltage fluctuation effects.

This implementation of multiple functions in one SMT package is ideal for applications ranging from cellular phones to PDAs and other small electronic devices.

2. Block Diagram

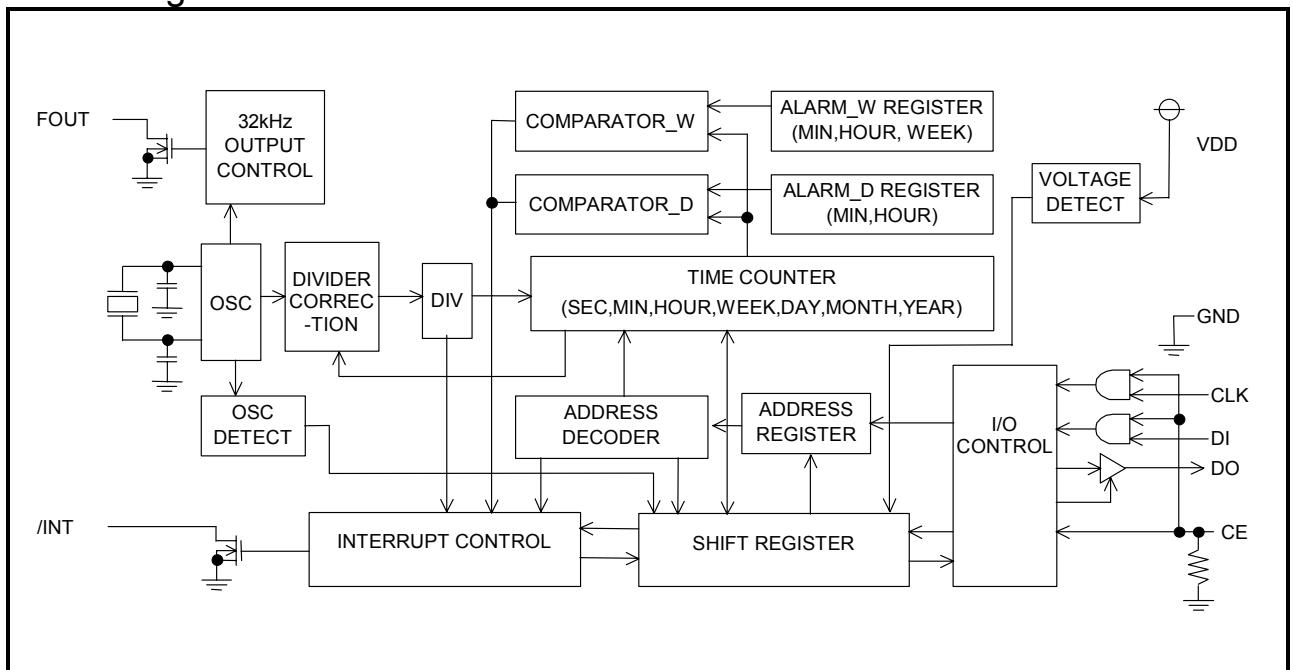

3. Description of Pins

3.1. Pin Layout

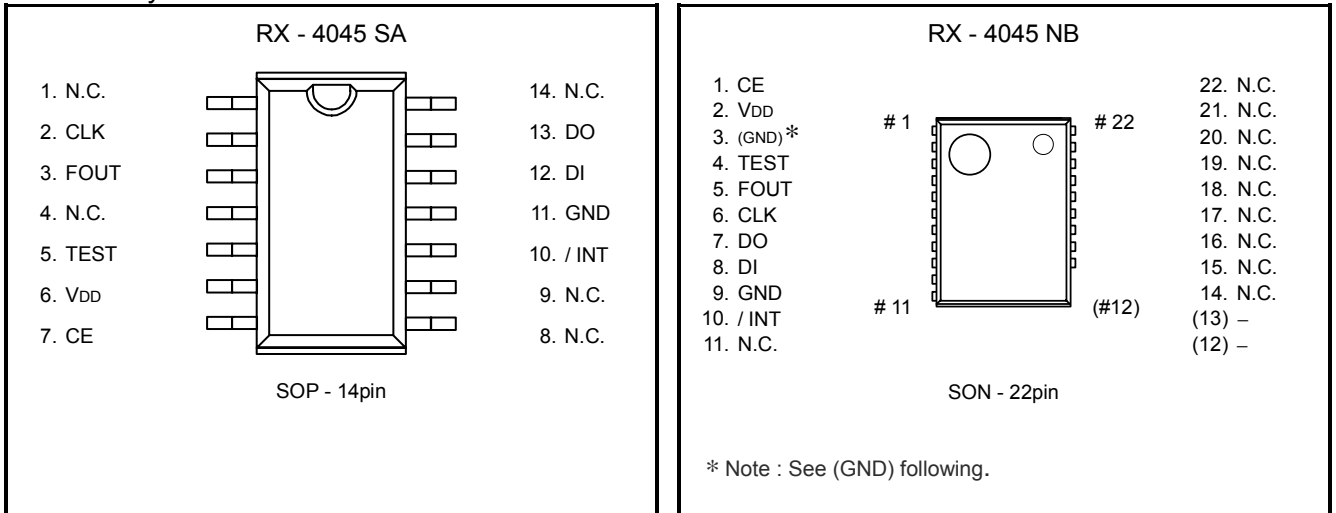

3.2. Pin Functions

Signal name	I / O	Function															
CE	I	The CE pin is used for interfacing with the CPU. Should be held high to allow access to the CPU. Incorporates a pull-down resistor. Should be held low or open when the CPU is powered off. Allows a maximum input voltage of 5.5 V regardless of supply voltage.															
CLK	I	The CLK pin is used to input clock pulses synchronizing the input and output of data to and from the DI and DO pins. Allows a maximum input voltage of 5.5 Vv regardless of supply voltage.															
DI	I	The DI pin is used to input data intended for writing in synchronization with the CLK pin. CMOS input. Allows a maximum input voltage of 5.5 V regardless of supply voltage.															
DO	O	The DO pin is used to output data intended for reading in synchronization with the CLK pin. CMOS output.															
FOUT	O	<p>This is a 32.768-kHz clock output pin (N-ch open drain), for which output control is provided. The output ON/OFF setting is controlled via the /CLEN1 and /CLEN2 bits; when either of these bits = 0, a 32.768-kHz signal is output from the FOUT pin. When output is stopped, high impedance is set.</p> <table border="1" style="margin-left: auto; margin-right: auto; border-collapse: collapse;"> <thead> <tr> <th style="width: 15%;">/CLEN1 bit</th> <th style="width: 15%;">/CLEN2 bit</th> <th style="width: 70%;">FOUT output</th> </tr> </thead> <tbody> <tr> <td style="text-align: center;">0</td> <td style="text-align: center;">0</td> <td style="text-align: center;">32.768 kHz</td> </tr> <tr> <td style="text-align: center;">0</td> <td style="text-align: center;">1</td> <td style="text-align: center;">32.768 kHz</td> </tr> <tr> <td style="text-align: center;">1</td> <td style="text-align: center;">0</td> <td style="text-align: center;">32.768 kHz</td> </tr> <tr> <td style="text-align: center;">1</td> <td style="text-align: center;">1</td> <td style="text-align: center;">OFF (Hi-z)</td> </tr> </tbody> </table> <p>However it cannot be pulled up over VDD+0.3v.</p>	/CLEN1 bit	/CLEN2 bit	FOUT output	0	0	32.768 kHz	0	1	32.768 kHz	1	0	32.768 kHz	1	1	OFF (Hi-z)
/CLEN1 bit	/CLEN2 bit	FOUT output															
0	0	32.768 kHz															
0	1	32.768 kHz															
1	0	32.768 kHz															
1	1	OFF (Hi-z)															
/INT	O	<p>This interrupt output A pin is an N-ch open drain output. This pin is able to output at low level when an interrupt occurs. When output is OFF or when the power supply starts up from 0 V, high impedance is set. Allows a maximum pull-up voltage of 5.5v regardless of supply voltage.</p>															
TEST	-	The factory testing uses this pin. Do not connect externally.															
VDD	-	This pin is connected to a positive power supply.															
GND	-	This pin is connected to a ground.															
(GND)	-	This pin has the same voltage level as GND. Do not connect externally.															
N.C.	-	<p>This pin is not connected to the internal IC. However, note with caution that the RX-4025NB's N.C. pins (pins 14 to 22) are interconnected via the internal frame. Leave N.C. pins open or connect them to GND or VDD.</p>															

Note: Be sure to connect a bypass capacitor rated at least 0.1 μF between VDD and GND.

4. Absolute Maximum Ratings

GND = 0 V

Item	Symbol	Condition	Rating	Unit
Supply voltage	V _{DD}	Between V _{DD} and GND	-0.3 to +6.5	V
Input voltage	V _I	CE, CLK, DI pins	GND-0.3 to +6.5	V
Output voltage	V _{O1}	FOUT, /INT pins	GND-0.3 to +6.5	V
	V _{O2}	DO pin	GND-0.3 to V _{DD} +0.3	V
Storage temperature	T _{STG}	When stored separately, without packaging	-55 to +125	°C

5. Recommended Operating Conditions

GND = 0 V

Item	Symbol	Condition	Min.	Typ.	Max.	Unit
Operating supply voltage	V _{DD}	-	1.7	3.0	5.5	V
Clock supply voltage	V _{CLK}	-	1.15	3.0	5.5	V
Applied voltage when OFF	V _{PUP}	/INT pin	GND-0.3		5.5	°C
Operating temperature	T _{OPR}	No condensation	-40	+25	+85	°C

6. Frequency Characteristics

GND = 0 V

Item	Symbol	Condition	Rating	Unit
Frequency precision	$\Delta f / f$	T _a = +25 °C V _{DD} = 3.0 V	AA ; 5 ± 5 ^(*1) AC ; 0 ± 5 ^(*1)	× 10 ⁻⁶
Frequency/voltage characteristics	f / V	T _a = +25 °C V _{DD} = 2 V to 5 V	± 1 Max.	× 10 ⁻⁶ / V
Frequency/temperature characteristics	T _{op}	T _a = -20 °C to +70 °C, V _{DD} = 3.0 V; +25 °C reference	+10 / -120	× 10 ⁻⁶
Oscillation start time	t _{STA}	T _a = +25 °C V _{DD} = 2.0 V	1 Max.	s
Aging	f _a	T _a = +25 °C V _{DD} = 3.0 V; first year	± 5 Max.	× 10 ⁻⁶ / year

*1) AC rank. Precision gap per month: 13 seconds (excluding offset value)

7. Electrical Characteristics

7.1. DC Electrical Characteristics

7.1.1. DC electrical characteristics (1) * Unless otherwise specified, GND = 0 V, V_{DD} = 3 V, Ta = -40 °C to +85 °C

Item	Symbol	Condition	Min.	Typ.	Max.	Unit	
Current (1)	I _{DD1}	FOUT, /INT = OFF. CE, CLK, DI, DO = GND	V _{DD} =5 V		0.60	1.80	μA
			V _{DD} =3 V		0.48	1.20	
Current (2)	I _{DD2}	FOUT = ON CE, CLK, DI, DO = GND	V _{DD} =3 V		0.65	2.00	μA
High-level input voltage	V _{IH}	CE, CLK, DI pins V _{DD} = 1.7 to 5.5 V	0.8 × V _{DD}		5.5	V	
Low-level input voltage	V _{IL}		GND - 0.3		0.2 × V _{DD}	V	
High-level input current	I _{OH}	DO pin, V _{OH} = V _{DD} - 0.5 V			-0.5	mA	
Low-level input current	I _{OL1}	/INT pin, V _{OL} = 0.4 V	2.0			mA	
	I _{OL2}	DO, FOUT pins, V _{OL} = 0.4 V	0.5			mA	
Input leakage current	I _{IL}	CLK pin V _I = 5.5 V or GND, V _{DD} = 5.5 V	-1		1	μA	

7.1.2. DC electrical characteristics (2) * Unless otherwise specified, GND = 0 V, V_{DD} = 3 V, Ta = -40 °C to +85 °C

Item	Symbol	Condition	Min.	Typ.	Max.	Unit	
Pull-down resistor	R _{DNCE}	CE pin	40	120	400	kΩ	
Output current when OFF	I _{OZ1}	DO pin V _O = 5.5 V or GND, V _{DD} = 5.5 V	-1		1	μA	
		FOUT, /INT pins V _O = 5.5 V	-1		1	μA	
Power supply detection voltage	High-voltage mode	V _{DETH}	V _{DD} pin, Ta = -30 to +70 °C	1.90	2.10	2.30	V
	Low-voltage mode	V _{DETL}	V _{DD} pin, Ta = -30 to +70 °C	1.15	1.30	1.45	V

7.2. AC Electrical Characteristics

* Unless otherwise specified: GND = 0 V, VDD = 1.7 V to 5.5 V, Ta = -40 °C to +85 °C

* Input conditions: VIH = 0.8 × VDD, VIL = 0.2 × VDD, VOH = 0.8 × VDD, VOL = 0.2 × VDD, CL = 50 pF

Item	Symbol	Condition	Min.	Typ.	Max.	Unit
CE setup time	tCES		400			ns
CE hold time	tCEH		400			ns
CE recovery time	tCR		62			μs
CLK clock frequency	fCLK				1.0	MHz
CLK "H" pulse width	tCKH		400			ns
CLK "L" pulse width	tCKL		400			ns
CLK setup time	tCKS		200			ns
Data output delay time	tRD				300	ns
Data output floating time	tRZ				300	ns
Data output floating time after falling if CE	tCEZ				300	ns
Input data setup time	tDS		200			ns
Input data hold time	tDH		200			ns

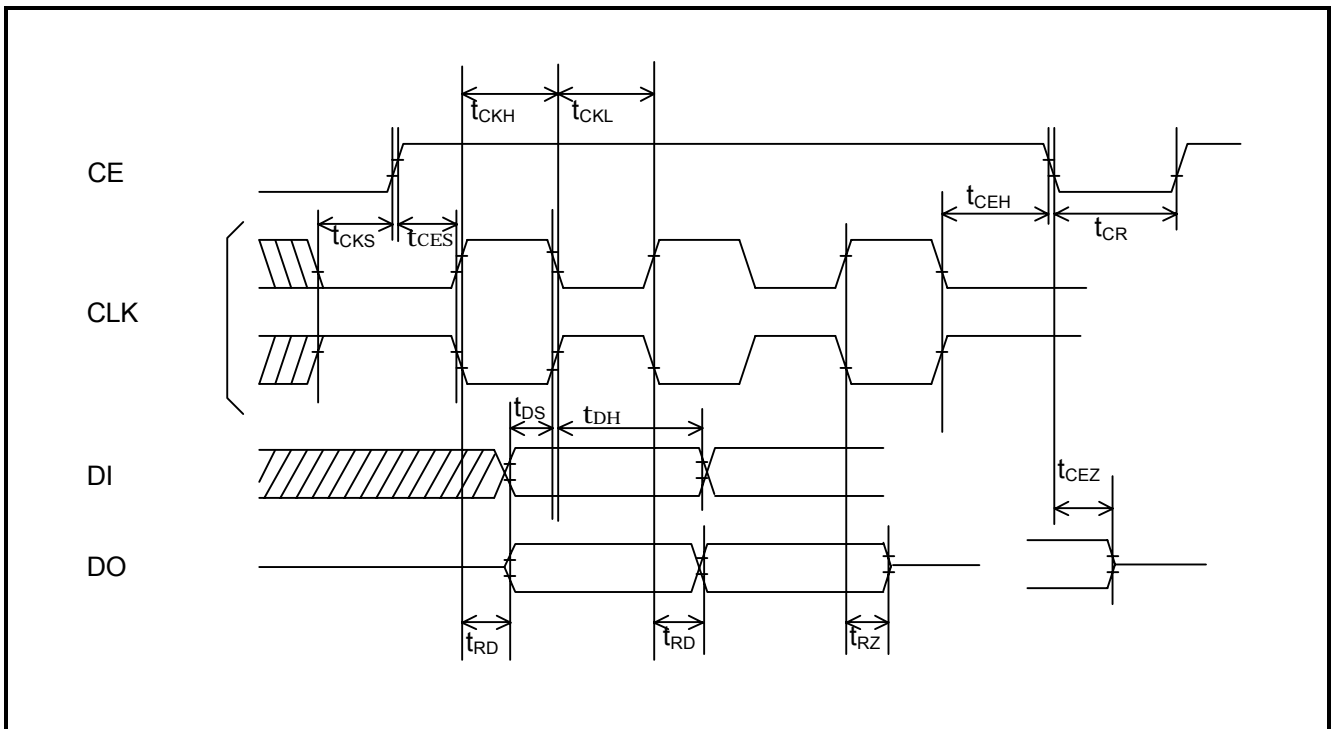

8. Functional descriptions

8.1. Overview of Functions

1) Clock functions

This function is used to set and read out month, date, day, hour, minute, and second.

Any (two-digit) year that is a multiple of 4 is treated as a leap year and calculated automatically as such until the year 2099.

* For details, see "8.2. Description of Registers".

2) Clock precision adjustment function

The clock precision can be adjusted forward or back in units of $\pm 3.05 \times 10^{-6}$. This function can be used to implement a higher-precision clock function, such as by:

- enabling higher clock precision throughout the year by taking seasonal clock precision adjustments into account in advance, or
- enabling correction of temperature-related clock precision variation in systems that include a temperature detection function.

Note: Only the clock precision can be adjusted. The adjustments have no effect on the 32.768-kHz output from the FOUT pin.

* For details, see "8.3. Clock Precision Adjustment Function".

3) Periodic interrupt function

In addition to the alarm function, Periodic interrupts can be output via the /INT pin.

Select among five Periodic frequency settings: 2 Hz, 1 Hz, 1/60 Hz, hourly, or monthly.

Select among two output waveforms for periodic interrupts: an ordinary pulse waveform (2 Hz or 1 Hz) or a waveform (every second, minute, hour, or month) for CPU-level interrupts that can support CPU interrupts.

A polling function is also provided to enable monitoring of pin states via registers.

* For details, see "8.4. Periodic Interrupt Function".

4) Alarm functions

This module is equipped with two alarm functions (Alarm W and Alarm D) that output interrupt signals to the host at preset times. The Alarm W function can be used for day, hour, and minute-based alarm settings, and it outputs interrupt signals via the /INT pin. Multiple day settings can be selected (such as Monday, Wednesday, Friday, Saturday, and Sunday). The Alarm D function can be used only for hour or minute-based settings, and it outputs interrupt signals via the /INT pin.

A polling function is also provided to enable checking of each alarm mode by the host.

* For details on the Alarm W function, see "8.5. Alarm W function" and for the Alarm D function, see "8.6. Alarm D Function".

5) Oscillation stop detection function, power drop detection function (voltage monitoring function), and power-on reset detection function

The oscillation stop detection function uses registers to record when oscillation has stopped.

The power drop detection function (supply voltage monitoring function) uses registers to record when the supply voltage drops below a specified voltage threshold value. Use registers to specify either of two voltage threshold values: 2.1 V or 1.3 V. Voltage sampling is performed once per second in consideration of the module's low current consumption.

While the oscillation stop detection function is useful for determining when clock data has become invalid, the supply voltage monitoring function is useful for determining whether or not the clock data is able to become invalid. The supply voltage monitoring function can also be used to monitor a battery's supply voltage.

When these functions are utilized in combination with the power-on reset detection function, they are useful for determining whether clock data is valid or invalid when checking for power-on from 0 V or for back-up.

* For details, see "8.7. Detection Functions".

6) Interface with CPU

The RX-4045 is connected to the CPU by four signal lines CE (Chip Enable), CLK (Clock), DI (Data Input), and DO (Data Output), through which it reads and writes data from and to the CPU.

The CPU can be accessed when the CE pin is held high. Access clock pulses have a maximum frequency of 1 MHz allowing high-speed data transfer to the CPU.

* For further description of data read/write operations, see "8.9. Read/Write of data".

7) 32.768-kHz clock output

The 32.768-kHz clock (with precision equal to that of the built-in quartz oscillator) can be output via the FOUT pin.

Note: The precision of this 32.768-kHz clock output via the FOUT pin cannot be adjusted (even when using the clock precision adjustment function).

8.2. Description of Registers

8.2.1. Register table

Address	Function	bit 7	bit 6	bit 5	bit 4	bit 3	bit 2	bit 1	bit 0	note
0	Seconds	○	S40	S20	S10	S8	S4	S2	S1	*5
1	Minutes	○	M40	M20	M10	M8	M4	M2	M1	*5
2	Hours	○	○	H20 P, /A	H10	H8	H4	H2	H1	*5
3	Weekdays	○	○	○	○	○	W4	W2	W1	*5
4	Days	○	○	D20	D10	D8	D4	D2	D1	*5
5	Months	0	○	○	MO10	MO8	MO4	MO2	MO1	*4, *5
6	Years	Y80	Y40	Y20	Y10	Y8	Y4	Y2	Y1	—
7	Digital Offset	0	F6	F5	F4	F3	F2	F1	F0	*4
8	Alarm_W ; Minute	○	WM40	WM20	WM10	WM8	WM4	WM2	WM1	*5
9	Alarm_W ; Hour	○	○	WH20 WP, /A	WH10	WH8	WH4	WH2	WH1	*5
A	Alarm_W ; Weekday	○	WW6	WW5	WW4	WW3	WW2	WW1	WW0	*5
B	Alarm_D ; Minute	○	DM40	DM20	DM10	DM8	DM4	DM2	DM1	*5
C	Alarm_D ; Hour	○	○	DH20 DP, /A	DH10	DH8	DH4	DH2	DH1	*5
D	Reserved	Reserved								*3
E	Control 1	WALE	DALE	/12, 24	/CLEN2	TEST	CT2	CT1	CT0	*1, *2, *6
F	Control 2	VDSL	VDET	/XST	PON	/CLEN1	CTFG	WAFG	DAFG	*1, *6

Caution points:

- The PON bit is a power-on reset flag bit.
The PON bit is set to "1" when a reset occurs, such as during the initial power-up or when recovering from a supply voltage drop. At the same time, all bits in the Control 1 and Control 2 registers except for the PON and /XST bits are reset to "0".
Note: At this point, all other register values are undefined, so be sure to perform a reset before using the module.
Also, be sure to avoid entering incorrect date and time data, as clock operations are not guaranteed when the time data is incorrect.
- The TEST bit is used by the manufacturer for testing. Be sure to set "0" for this bit.
- Address D (a reserved register) is used for the manufacturer's settings. Do not read from or write to this register.
- All bits marked with a "0" in the above table should be set as "0". Their value when read will be "0".
- All bits marked with "○" are read-only bits. Their value when read is always "0".
- When PON bit became 1 because power-on reset function worked, /CLEN1 and /CLEN2 bit become 0.
When /CLEN1 and /CLEN2 bit become 1, FOUT output stops.

/CLEN1 bit	/CLEN2 bit	FOUT output
X	X	OFF (" L ")
0	0	32.768 kHz
0	1	32.768 kHz
1	0	32.768 kHz
1	1	OFF (" Hi-z ")

'X' Don't care.

8.2.2. Time counter (Reg 0 to 2)

Address	Function	bit 7	bit 6	bit 5	bit 4	bit 3	bit 2	bit 1	bit 0
0	Seconds	○	S40	S20	S10	S8	S4	S2	S1
1	Minutes	○	M40	M20	M10	M8	M4	M2	M1
2	Hours	○	○	H20 P, /A	H10	H8	H4	H2	H1

- The time counter counts seconds, minutes, and hours.
 - The data format is BCD format (except during 12-hour mode). For example, when the "seconds" register value is "0101 1001" it indicates 59 seconds.
- * Note with caution that writing non-existent time data may interfere with normal operation of the time counter.

1) Second counter

Address	Function	bit 7	bit 6	bit 5	bit 4	bit 3	bit 2	bit 1	bit 0
0	Seconds	○	S40	S20	S10	S8	S4	S2	S1

- This second counter counts from "00" to "01," "02," and up to 59 seconds, after which it starts again from 00 seconds.
- When a value is written to the second counter, the internal counter is also reset to zero in less than one second.

2) Minute counter

Address	Function	bit 7	bit 6	bit 5	bit 4	bit 3	bit 2	bit 1	bit 0
1	Minutes	○	M40	M20	M10	M8	M4	M2	M1

- This minute counter counts from "00" to "01," "02," and up to 59 minutes, after which it starts again from 00 minutes.

3) Hour counter

Address	Function	bit 7	bit 6	bit 5	bit 4	bit 3	bit 2	bit 1	bit 0
2	Hours	○	○	H20 P, /A	H10	H8	H4	H2	H1

- The hour counter counts hours, and its clock mode differs according to the value of its /12,24 bit.
- During 24-hour clock operation, bit 5 functions as H20 (two-digit hour display). During 12-hour clock operation, bit 5 functions as an AM/PM indicator ("0" indicates AM and "1" indicates PM).

/12,24 bit	Description	Address 2 (Hours register) data [h] during 24-hour and 12-hour clock operation modes			
		24-hour clock		12-hour clock	
0	12-hour clock	00	12 (AM 12)	12	32 (PM 12)
		01	01 (AM 01)	13	21 (PM 01)
		02	02 (AM 02)	14	22 (PM 02)
		03	03 (AM 03)	15	23 (PM 03)
		04	04 (AM 04)	16	24 (PM 04)
		05	05 (AM 05)	17	25 (PM 05)
1	24-hour clock	06	06 (AM 06)	18	26 (PM 06)
		07	07 (AM 07)	19	27 (PM 07)
		08	08 (AM 08)	20	28 (PM 08)
		09	09 (AM 09)	21	29 (PM 09)
		10	10 (AM 10)	22	30 (PM 10)
		11	11 (AM 11)	23	31 (PM 11)

8.2.3. Day counter (Reg 3)

Address	Function	bit 7	bit 6	bit 5	bit 4	bit 3	bit 2	bit 1	bit 0
3	Days	○	○	○	○	○	W4	W2	W1

- The day counter is a divide-by-7 counter that counts from 00 to 01 and up 06 before starting again from 01.
- The correspondence between days and count values is shown below.

Days	W4	W2	W1	Day	Remark
Write / Read	0	0	0	Sunday	00 h
	0	0	1	Monday	01 h
	0	1	0	Tuesday	02 h
	0	1	1	Wednesday	03 h
	1	0	0	Thursday	04 h
	1	0	1	Friday	05 h
	1	1	0	Saturday	06 h
Write prohibit	1	1	1	–	Do not enter a setting for this bit.

8.2.4. Calendar counter (Reg 4 to 6)

Address	Function	bit 7	bit 6	bit 5	bit 4	bit 3	bit 2	bit 1	bit 0
4	Days	○	○	D20	D10	D8	D4	D2	D1
5	Months	0	○	○	MO10	MO8	MO4	MO2	MO1
6	Years	Y80	Y40	Y20	Y10	Y8	Y4	Y2	Y1

- The auto calendar function updates all dates, months, and years from January 1, 2001 to December 31, 2099.
- The data format is BCD format. For example, a date register value of "0011 0001" indicates the 31st.
- * Note with caution that writing non-existent date data may interfere with normal operation of the calendar counter.

1) Date counter

Address	Function	bit 7	bit 6	bit 5	bit 4	bit 3	bit 2	bit 1	bit 0
4	Days	○	○	D20	D10	D8	D4	D2	D1

- The updating of dates by the date counter varies according to the month setting.
- * A leap year is set whenever the year value is a multiple of four (such as 04, 08, 12, 88, 92, or 96).

Days	Month	Date update pattern
Write / Read	1, 3, 5, 7, 8, 10, or 12	01, 02, 03 to 30, 31, 01...
	4, 6, 9, or 11	01, 02, 03 to 30, 01, 02...
	February in leap year	01, 02, 03 to 28, 29, 01...
	February in normal year	01, 02, 03 to 28, 01, 02...

2) Month counter

Address	Function	bit 7	bit 6	bit 5	bit 4	bit 3	bit 2	bit 1	bit 0
5	Months	0	○	○	MO10	MO8	MO4	MO2	MO1

- The month counter counts from 01 (January), 02 (February), and up to 12 (December), then starts again at 01 (January).
- * Be sure to set a "0" for any bit whose value is shown above as "0". A zero is returned when any of these bits is read.

3) Year counter

Address	Function	bit 7	bit 6	bit 5	bit 4	bit 3	bit 2	bit 1	bit 0
6	Years	Y80	Y40	Y20	Y10	Y8	Y4	Y2	Y1

- The year counter counts from 00, 01, 02 and up to 99, then starts again at 00.
- * In any year that is a multiple of four (04, 08, 12, 88, 92, 96, etc.), the dates in February are counted from 01, 02, 03 and up to 29 before starting again at 01.

8.2.5. Clock precision adjustment register (Reg 7)

Address	Function	bit 7	bit 6	bit 5	bit 4	bit 3	bit 2	bit 1	bit 0
7	Digital Offset (Default)	0 (0)	F6 (0)	F5 (0)	F4 (0)	F3 (0)	F2 (0)	F1 (0)	F0 (0)

- The binary encoded settings in the seven bits from F6 to F0 are used to set the precision of the clock generated from the 32768-Hz internal oscillator up to $\pm 189 \times 10^{-6}$ in the forward (ahead) or reverse (behind) direction, in units of $\pm 3.05 \times 10^{-6}$. (Only the clock precision can be adjusted. The 32.768-kHz output from the FOUT pin is not affected.)
- When not using this function, be sure to set "0" for bits F6 to F0.

* For details, see "8.3. Clock Precision Adjustment Function".

8.2.6. Alarm_W register (Reg 8 to A)

Address	Function	bit 7	bit 6	bit 5	bit 4	bit 3	bit 2	bit 1	bit 0
8	Alarm_W ; Minute	○	WM40	WM20	WM10	WM8	WM4	WM2	WM1
9	Alarm_W ; Hour	○	○	WH20 WP, /A	WH10	WH8	WH4	WH2	WH1
A	Alarm_W ; Day	○	WW6	WW5	WW4	WW3	WW2	WW1	WW0

- The Alarm W function is used, along with the WALE and WAFG bits, to set alarms for specified day, hour, and minute values.
- When the Alarm_W setting matches the current time, /INT pin is set to "L" and the WALE bit is set to "1".
Note: If the current date/time is used as the Alarm_W setting, the alarm will not occur until the counter counts up to the current date/time (i.e., an alarm will occur next time, not immediately).
- During 24-hour clock operation, the "Alarm_W ; Hours" register's bit 5 (WH20, WP, /A) functions as WH20 (two-digit hour display), and during 12-hour clock operation it functions as an AM/PM indicator.
- When the Alarm_W function's day values (WW6 to WW0) are all "0" Alarm W does not occur.

* For details, see "8.5. Alarm W Function".

8.2.7. Alarm_D register (Reg B and C)

Address	Function	bit 7	bit 6	bit 5	bit 4	bit 3	bit 2	bit 1	bit 0
B	Alarm_D ; Minute	○	DM40	DM20	DM10	DM8	DM4	DM2	DM1
C	Alarm_D ; Hour	○	○	DH20 DP, /A	DH10	DH8	DH4	DH2	DH1

- The Alarm D function is used, along with the DALE and DAFG bits, to set alarms for specified hour and minute values.
- When the Alarm_D setting matches the current time, /INT pin is set to "L" and the DALE bit is set to "1".
Note: If the current time is used as the Alarm_D setting, the alarm will not occur until the counter counts up to the current time (i.e., an alarm will occur next time, not immediately).
- During 24-hour clock operation, the "Alarm_D ; Hours" register's bit 5 (DH20, DP, /A) functions as DH20 (two-digit hour display), and during 12-hour clock operation it functions as an AM/PM indicator.

* For details, see "8.6. Alarm D Function".

8.2.8. Control register 1 (Reg E)

Address	Function	bit 7	bit 6	bit 5	bit 4	bit 3	bit 2	bit 1	bit 0
E	Control 1 (Default)	WALE (0)	DALE (0)	/12, 24 (0)	/CLEN2 (0)	TEST (0)	CT2 (0)	CT1 (0)	CT0 (0)

*) The default value is the value that is read (or is set internally) after the PON bit has been set to "1," such as after powering up from 0 V or recovering from a supply voltage drop.

1) WALE bit

This bit is used to set up the Alarm W function (to generate alarms matching day, hour, or minute settings).

WALE	Data	Description
Write / Read	0	Alarm_W, match comparison operation invalid * Default
	1	Alarm_W, match comparison operation valid (/INT = "L" when match occurs)

* For details, see "8.5. Alarm W Function".

2) DALE bit

This bit is used to set up the Alarm D function (to generate alarms matching hour or minute settings).

DALE	Data	Description
Write / Read	0	Alarm_D, match comparison operation invalid * Default
	1	Alarm_D, match comparison operation valid (/INT = "L" when match occurs)

* For details, see "8.6. Alarm D Function".

3) /12,24 bit

This bit is used to select between 12-hour clock operation and 24-hour clock operation.

/12,24	Data	Description
Write / Read	0	12-hour clock * Default
	1	24-hour clock

* Be sure to select between 12-hour and 24-hour clock operation before writing the time data.

* See also "3) Hour counter" in section 8.2.4.

4) /CLEN2 bit

It combines /CLEN1 bit, and is bit controlling FOUT output.

When /CLEN1 and /CLEN2 bit become 1, FOUT output stops.

When PON bit became 1 because power-on reset function worked, /CLEN1 and /CLEN2 bit become 0.

5) TEST bit

This bit is used by the manufacturer for testing. Be sure to write "0" to this bit.

Be careful to avoid writing a "1" to this bit when writing to other bits.

TEST	Data	Description
Write / Read	0	Normal operation mode * Default
	1	Setting prohibited (manufacturer's test mode)

6) CT2, CT1, and CT0 bits

These bits are used to set up the operation of the periodic interrupt function that uses the /INT pin.

CT2	CT1	CT0	/INT pin's output setting	
			Waveform mode	Cycle/Fall timing
0	0	0	–	/INT = Hi-Z (= OFF) * Default
0	0	1	–	/INT = Fixed low
0	1	0	Pulse mode *1)	2 Hz (50% duty)
0	1	1	Pulse mode *1)	1 Hz (50% duty)
1	0	0	Level mode *2)	Once per second (Synchronous with per-second count-up)
1	0	1	Level mode *2)	Once per minute (Occurs when seconds reach ":00")
1	1	0	Level mode *2)	Once per hour (Occurs when minutes and seconds reach "00:00")
1	1	1	Level mode *2)	Once per month (Occurs at 00:00:00 on first day of month)

* For details, see "8.4. Periodic Interrupt".

8.2.9. Control register 2 (Reg F)

Address	Function	bit 7	bit 6	bit 5	bit 4	bit 3	bit 2	bit 1	bit 0
F	Control 2 (Default)	VDSL (0)	VDET (0)	/ XST (-)	PON (1)	/CLEN1 (0)	CTFG (0)	WAFG (0)	DAFG (0)

*1) The default value is the value that is read (or is set internally) after the PON bit has been set to "1," such as after powering up from 0 V or recovering from a supply voltage drop.

*2) "-" indicates undefined status.

1) VDSL bit

This bit is used to set the power drop detection function's threshold voltage value.

VDSL	Data	Description
Write / Read	0	Sets 2.1 V as the power drop detection function's threshold voltage value * Default
	1	Sets 1.3 V as the power drop detection function's threshold voltage value

* For details, see "8.7. Detection Functions".

2) VDET bit

This bit indicates the power drop detection function's detection results.

VDET = "1" once a power voltage drop has occurred.

VDET	Data	Description
Write	0	Clears the VDET bit to zero, restarts the power drop detection operation and sets up for next power drop detection operation * Default
	1	Setting prohibited (do not set this bit value, even though it has no effect)
Read	0	Power drop was not detected * Default
	1	Power drop was detected (result is that bit value is held until cleared to zero)

* For details, see "8.7. Detection Functions".

3) / XST bit

This bit indicates the oscillation stop detection function's detection results.

If a "1" has already been written to this bit, it is cleared to zero when stopping of internal oscillation is detected.

/ XST	Data	Description
Write	0	Setting prohibited (do not set this bit value, even though it has no effect)
	1	Sets the oscillation stop detection function as use-enabled and sets up for next detection operation
Read	0	Oscillation stop was detected (result is that bit value is held until a "1" is written)
	1	Oscillation stop was not detected

* For details, see "8.7. Detection Functions".

4) PON bit

This bit indicates the power-on reset detection function's detection results.

The PON bit is set (= 1) when the internal power-on reset function operates.

PON	Data	Description
Write	0	Clears the PON bit to zero and sets up next detection operation
	1	Setting prohibited (do not set this bit value, even though it has no effect)
Read	0	Power-on reset was not detected
	1	Power-on reset was detected (result is that bit value is held until cleared to zero) * Default

* When PON = "1" all bits in the Clock Precision Adjustment register and in the Control 1 and Control 2 registers (except for the PON and / XST bits) are reset to "0". This also causes output from /INT and /INT pin to be stopped (= Hi-Z).

* For details, see "8.7. Detection Functions".

5) /CLEN1 bit

This bit is controlling FOUT output with /CLEN2 bit.

When /CLEN1 and /CLEN2 bit set to 1, FOUT output stops.

When PON bit became 1 because power-on reset function worked, /CLEN1 and /CLEN2 bit become 0.

6) CTFG bit

During a read operation, this bit indicates the /INT pin's periodic interrupt output status.

This status can be set as OFF by writing a "0" to this bit when /INT = "L".

CTFG	Data	Description
Write	0	A "0" can be written only when the periodic interrupt is in level mode, at which time the /INT pin is set to OFF (Hi-z) status. (Only when Alarm_D does not match) * Default * After a "0" is written, the value still becomes "1" again at the next cycle.
	1	Setting prohibited (do not set this bit value, even though it has no effect)
Read	0	Periodic interrupt output OFF status; /INT = OFF (Hi-z) * Default
	1	Periodic interrupt output ON status; /INT = "L"

* For details, see "8.4. Periodic Interrupt Function".

7) WAFG bit

This bit is valid only when the WALE bit value is "1". The WAFG bit value becomes "1" when Alarm W has occurred.

The /INT = "L" status that is set at this time can be set to OFF by writing a "0" to this bit.

WAFG	Data	Description
Write	0	/INT pin = OFF (Hi-z) * Default
	1	Setting prohibited (do not set this bit value, even though it has no effect)
Read	0	Alarm_W time setting does not match current time (This bit's value is always "0" when the WALE bit's setting is "0") * Default
	1	Alarm_W setting matches current time (Result is that bit value is held until cleared to zero)

* For details, see "8.5. Alarm W Function".

8) DAFG bit

This bit is valid only when the DALE bit value is "1". The DAFG bit value becomes "1" when Alarm D has occurred.

The /INT = "L" status that is set at this time can be set to OFF by writing a "0" to this bit.

DAFG	Data	Description
Write	0	/INT pin = OFF (Hi-z) (but only when the periodic interrupt output status is OFF) * Default
	1	Setting prohibited (do not set this bit value, even though it has no effect)
Read	0	Alarm_D time setting does not match current time (This bit's value is always "0" when the DALE bit's setting is "0") * Default
	1	Alarm_D time setting matches current time (result is that bit value is held until cleared to zero)

* For details, see "8.6. Alarm D function".

8.3. Clock Precision Adjustment Function

The clock precision can be set ahead or behind.

This function can be used to implement a higher-precision clock function, such as by:

- enabling higher clock precision throughout the year by taking seasonal clock precision adjustments into account in advance, or
- enabling correction of temperature-related clock precision variation in systems that include a temperature detection function.

* Note: Only the clock precision can be adjusted. The adjustments have no effect on the 32.768-kHz output from the FOUT pin.

8.3.1. Related register

Address	Function	bit 7	bit 6	bit 5	bit 4	bit 3	bit 2	bit 1	bit 0
7	Digital Offset (Default)	0 (0)	F6 (0)	F5 (0)	F4 (0)	F3 (0)	F2 (0)	F1 (0)	F0 (0)

*) Be sure to set a "0" for any bit whose value is shown above as "0". A zero is returned when any of these bits is read.

- The binary encoded settings in the seven bits from F6 to F0 are used to set the precision of the clock generated from the 32768-Hz internal oscillator up to $\pm 189.1 \times 10^{-6}$ in the forward (ahead) or reverse (behind) direction, in units of $\pm 3.05 \times 10^{-6}$.

*1) When not using this function, be sure to set "0" for bits F6 to F0.

*2) This function operates every twenty seconds (at 00 seconds, 20 seconds, and 40 seconds within each minute), which changes the cycle of the periodic interrupts that occur via this timing. (See "8.4. Periodic Interrupt Function".)

8.3.2. Adjustment capacity

1) Adjustment range and resolution

Adjustment range	Adjustment resolution	Internal timing of adjustment
-189.1×10^{-6} to $+189.1 \times 10^{-6}$	$\pm 3.05 \times 10^{-6}$	Once every 20 seconds (at "00", "20" and "40" seconds)

2) Adjustment amount and adjustment value

Adjustment amount ($\times 10^{-6}$)	Adjustment data Decimal / Hexadecimal	bit 7 0	bit 6 F6	bit 5 F5	bit 4 F4	bit 3 F3	bit 2 F2	bit 1 F1	bit 0 F0
-189.10	+63 / 3F h	0	0	1	1	1	1	1	1
-186.05	+62 / 3E h	0	0	1	1	1	1	1	0
-183.00	+61 / 3D h	0	0	1	1	1	1	0	1
⋮	⋮	⋮							
-9.15	+4 / 04	0	0	0	0	0	1	0	0
-6.10	+3 / 03	0	0	0	0	0	0	1	1
-3.05	+2 / 02 h	0	0	0	0	0	0	1	0
OFF	1 / 01 h	0	0	0	0	0	0	0	1
OFF	0 / 00 h	0	0	0	0	0	0	0	0
+3.05	-1 / 7F h	0	1	1	1	1	1	1	1
+6.10	-2 / 7E h	0	1	1	1	1	1	1	0
+9.15	-3 / 7D h	0	1	1	1	1	1	0	1
⋮	⋮	⋮							
+183.00	-60 / 44 h	0	1	0	0	0	1	0	0
+186.05	-61 / 43 h	0	1	0	0	0	0	1	1
+189.10	-62 / 42 h	0	1	0	0	0	0	1	0
OFF	-63 / 41 h	0	1	0	0	0	0	0	1
OFF	-64 / 40 h	0	1	0	0	0	0	0	0

8.3.3. Adjustment examples

Example 1) Setting time forward

Objective) To adjust (advance) the clock precision when FOUT clock output is 32767.7 Hz

(1) Determine the current amount of variance

$$32767.7 \text{ Hz} \rightarrow (32767.7 - 32768) / 32768 * [32768] = \text{Reference values}$$

$$\rightarrow -9.16 \times 10^{-6}$$

(2) Calculate the optimum adjustment data (decimal value) relative to the current variance.

$$\text{Adjustment data} = \text{variance} / \text{adjustment resolution}$$

$$= -9.16 / 3.05$$

$$\approx -3 \text{ (decimal values are rounded down from 4 and up from 5)}$$

* For adjusting forward from a retarded variance, this formula can be corrected using reciprocal numbers, but since this product inverts the +/- attributes, this formula can be used as it is.

(3) Calculate the setting adjustment data (hexadecimal)

To calculate the setting adjustment data while taking 7-bit binary encoding into account, subtract the adjustment data (decimal) from 128 (80h).

$$\text{Setting adjustment data} = 128 - 3 = 125 \text{ (decimal)}$$

$$= 80\text{h} - 03\text{h} = 7\text{Dh (hexadecimal)}$$

Example 2) Setting time backward

Objective) To adjust (set back) the clock precision when FOUT clock output is 32768.3 Hz

(1) Determine the current amount of variance

$$32768.3 \text{ Hz} \rightarrow (32768.3 - 32768) / 32768 * [32768] = \text{reference values}$$

$$\rightarrow +9.16 \times 10^{-6}$$

(2) Calculate the optimum adjustment data (decimal value) relative to the current variance.

$$\text{Adjustment data} = (\text{variance} / \text{adjustment resolution}) + 1$$

$$= (+9.16 / 3.05) + 1 \quad * \text{Add 1 since reference value is 01h}$$

$$\approx +4 \text{ (decimal values are rounded down from 4 and up from 5)}$$

* For adjusting backward from an advanced variance, this formula can be corrected using reciprocal numbers, but since this product inverts the +/- attributes, this formula can be used as it is.

(3) Calculate the setting adjustment data (hexadecimal)

The value "4" can be used in hexadecimal as it is (04h).

$$\text{Setting adjustment data} = 04 \text{ h (hexadecimal)}$$

8.4. Periodic Interrupt Function

Periodic interrupt output can be obtained via the /INT pin.

Select among five periodic-cycle settings: 2 Hz (once per 0.5 seconds), 1 Hz (once per second), 1/60 Hz (once per minute), 1/3600 Hz (once per hour), or monthly (on the 1st of each month).

Select among two output waveforms for periodic interrupts: an ordinary pulse waveform (2 Hz or 1 Hz) or a waveform (every second, minute, hour, or month) for CPU-level interrupts that can support CPU interrupts.

A polling function is also provided to enable monitoring of pin states via registers.

8.4.1. Related registers

Address	Function	bit 7	bit 6	bit 5	bit 4	bit 3	bit 2	bit 1	bit 0
E	Control 1 (Default)	WALE (0)	DALE (0)	/12, 24 (0)	/CLEN2 (0)	TEST (0)	CT2 (0)	CT1 (0)	CT0 (0)
F	Control 2 (Default)	VDSL (0)	VDET (0)	/XST (-)	PON (1)	/CLEN1 (0)	CTFG (0)	WAFG (0)	DAFG (0)

*1) The default value is the value that is read (or is set internally) after the PON bit has been set to "1," such as after powering up from 0 V or recovering from a supply voltage drop.

*2) "-" indicates undefined status.

1) CTFG bit

During a read operation, this bit indicates the /INT pin's periodic interrupt output status.

This status can be set as OFF by writing a "0" to this bit when /INT = "L".

CTFG	Data	Description
Write	0	A "0" can be written only when the periodic interrupt is in level mode, at which time the /INT pin is set to OFF (Hi-z) status. (Only when Alarm_D does not match) * After a "0" is written, the value still becomes "1" again at the next cycle. * Default
	1	Setting prohibited (do not set this bit value, even though it has no effect)
Read	0	periodic interrupt output OFF status; /INT = OFF (Hi-z) * Default
	1	Periodic interrupt output ON status; /INT = "L"

2) CT2, CT1, CT0 bit

Combinations of these three bits are used to change the /INT pin's output setting.

CT2	CT1	CT0	/INT pin's output setting	
			Waveform mode	Cycle / Fall timing
0	0	0	-	/INT = Hi-z (= OFF) * Default
0	0	1	-	/INT = Fixed low
0	1	0	Pulse mode *1)	2 Hz (50% duty)
0	1	1	Pulse mode *1)	1 Hz (50% duty)
1	0	0	Level mode *2)	Once per second (Synchronous with per-second count-up)
1	0	1	Level mode *2)	Once per minute (Occurs when seconds reach ":00")
1	1	0	Level mode *2)	Once per hour (Occurs when minutes and seconds reach "00:00")
1	1	1	Level mode *2)	Once per month (Occurs at 00:00:00 on first day of month)

* The /INT pin goes low ("L") when the Alarm_D function operates, but you can prevent that effect by setting "0" for CT2, CT1, and CT0 to stop this function.

* See the next page's description of pulse mode/level mode waveforms.

8.4.2. Mode-specific output waveforms

*1) Pulse mode

A 2-Hz or 1-Hz clock pulse is output.

The relation between the clock pulse and the count operation is shown below.

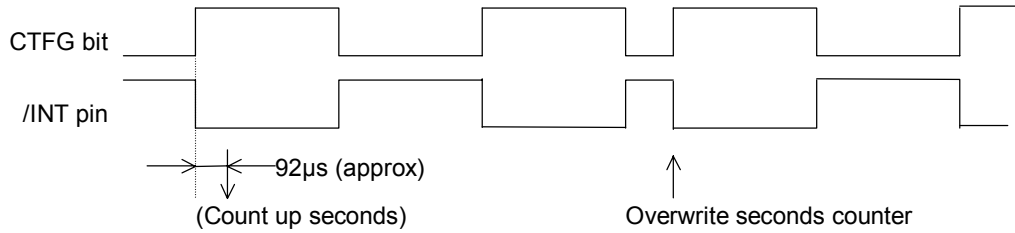

Note 1: As is shown in the above diagram, the seconds register's count up operation occurs approximately 92 µs after the falling edge of the /INT output. Therefore, if the clock's value is read immediately after the output's falling edge, the read clock value may appear to be about one second slower than the RTC module's clock value.

Note 2: When the seconds counter is overwritten, the counter for time values under one second is also reset, which causes the /INT level to go low ("L") again.

Note 3: When using the clock precision adjustment function, the periodic interrupt's cycle changes once every 20 seconds.

During pulse mode:

The period during which the output pulse is low can be adjusted backward or forward up to ±3.784 msec.

(For example, the duty for the 1-Hz setting can be adjusted ±0.3784% from 50%.)

*2) Level mode

Select among four interrupt cycles: one second, one minute, one hour, or one month.

Counting up of seconds occurs in sync with the falling edge of the interrupt output. The following is a timing chart when a one-second interrupt cycle has been set.

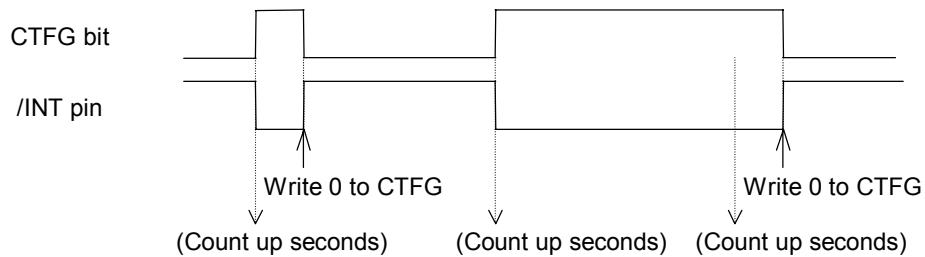

Note: When using the clock precision adjustment function, the periodic interrupt's cycle changes once every 20 seconds.

During level mode

A one-second period can be adjusted backward or forward up to ±3.784 msec.

8.5. Alarm W function

The Alarm W function generates interrupt signals (output via the /INT pin) that correspond to specified days, hours, and minutes.

For description of the Alarm D function, which supports only hour and minute data, see "8.6. Alarm D Function".

Multiple day settings can be selected (such as Monday, Wednesday, Friday, Saturday, and Sunday).

A polling function is also provided to enable checking of each alarm mode by the host.

8.5.1. Related registers

Address	Function	bit 7	bit 6	bit 5	bit 4	bit 3	bit 2	bit 1	bit 0
1	Minutes	○	M40	M20	M10	M8	M4	M2	M1
2	Hours	○	○	H20 P, /A	H10	H8	H4	H2	H1
3	Days	○	○	○	○	○	W4	W2	W1
8	Alarm_W ; Minute	○	WM40	WM20	WM10	WM8	WM4	WM2	WM1
9	Alarm_W ; Hour	○	○	WH20 WP, /A	WH10	WH8	WH4	WH2	WH1
A	Alarm_W ; Day	○	WW6	WW5	WW4	WW3	WW2	WW1	WW0
E	Control 1 (Default)	WALE (0)	DALE (0)	/12, 24 (0)	/CLEN2 (0)	TEST (0)	CT2 (0)	CT1 (0)	CT0 (0)
F	Control 2 (Default)	VDSL (0)	VDET (0)	/XST (-)	PON (1)	/CLEN1 (0)	CTFG (0)	WAFG (0)	DAFG (0)

*1) The default value is the value that is read (or is set internally) after the PON bit has been set to "1," such as after powering up from 0 V or recovering from a supply voltage drop.

*2) " " indicates write-protected bits. A zero is always read from these bits.

*3) "-" indicates undefined status.

- When the Alarm_W setting matches the current time, /INT pin is set to "L" and the WALE bit is set to "1".
Note: If the current date/time is used as the Alarm_W setting, the alarm will not occur until the counter counts up to the current date/time (i.e., an alarm will occur next time, not immediately).
- During 24-hour clock operation, the "Alarm_W ; Hours" register's bit 5 (WH20, WP, /A) functions as WH20 (two-digit hour display), and during 12-hour clock operation it functions as an AM/PM indicator.
- When the Alarm_W function's day values (WW6 to WW0) are all "0" Alarm W does not occur.

1) WALE bit

This bit is used to set up the Alarm W function (to generate alarms matching day, hour, or minute settings).

WALE	Data	Description
Write / Read	0	Alarm_W, match comparison operation invalid * Default
	1	Alarm_W, match comparison operation valid (/INT = "L" when match occurs)

* When using the Alarm W function, first set this WALE bit value as "0," then stop the function. Next, set the day, hour, minute, and the WAFG bit. Finally, set "1" to the WALE bit to set the Alarm W function as valid. The reason for first setting the WALE bit value as "0" is to prevent /INT = "L" output in the event that a match between the current time and alarm setting occurs while the alarm setting is still being made.

2) WAFG bit

This bit is valid only when the WALE bit value is "1". When a match occurs between the Alarm_W setting and the current time, the WAFG bit value becomes "1" approximately 61 μs afterward. (There is no effect when the WALE bit becomes "0".)

The /INT = "L" status that is set at this time can be set to OFF by writing a "0" to this bit.

WAFG	Data	Description
Write	0	/INT pin = OFF (Hi-z) * Default
	1	Setting prohibited (do not set this bit value, even though it has no effect)
Read	0	Alarm_W time setting does not match current time (This bit's value is always "0" when the WALE bit's setting is "0") * Default
	1	Alarm_W setting matches current time (Result is that bit value is held until cleared to zero)

* When a "0" is written to the WAFG bit, provisionally the WAFG bit value is "0" and the /INT pin status is OFF (Hi-z). However, as long as the WALE bit value is "1" the Alarm W function continues to operate, and Alarm W occurs again the next time the same specified time arrives. You can stop Alarm W from occurring by writing "0" to the WALE bit to set this function as invalid.

3) /12, 24 bit

This bit is used to select between 12-hour clock operation and 24-hour clock operation.

/12,24	Data	Description	Address 2 (Hours register) data [h] during 24-hour and 12-hour clock operation modes			
			24-hour clock		12-hour clock	
Write / Read	0	12-hour clock	00	12 (AM 12)	12	32 (PM 12)
			01	01 (AM 01)	13	21 (PM 01)
			02	02 (AM 02)	14	22 (PM 02)
			03	03 (AM 03)	15	23 (PM 03)
			04	04 (AM 04)	16	24 (PM 04)
			05	05 (AM 05)	17	25 (PM 05)
	1	24-hour clock	06	06 (AM 06)	18	26 (PM 06)
			07	07 (AM 07)	19	27 (PM 07)
			08	08 (AM 08)	20	28 (PM 08)
			09	09 (AM 09)	21	29 (PM 09)
			10	10 (AM 10)	22	30 (PM 10)
			11	11 (AM 11)	23	31 (PM 11)

* Be sure to select between 12-hour and 24-hour clock operation before writing the time data.

4) Day setting

The following table shows the correspondence between the current day (W4, W2, W1) and the Alarm_W day (WW6 to WW0). Be sure to set a "1" to the Alarm_W day when the alarm will occur. (An alarm will not occur for any day that has a "0" setting.)

It is possible to enter settings for several days at the same time, in which case be sure to set a "1" for each day (among WW6 to WW0) in which an alarm will occur.

Function	bit 7	bit 6	bit 5	bit 4	bit 3	bit 2	bit 1	bit 0
Alarm_W ; Day	□	WW6	WW5	WW4	WW3	WW2	WW1	WW0
Target day(s) (W4,W2,W1)	-	Saturday (1, 1, 0)	Friday (1, 0, 1)	Thursday (1, 0, 0)	Wednesday (0, 1, 1)	Tuesday (0, 1, 0)	Monday (0, 0, 1)	Sunday (0, 0, 0)

8.5.2. Alarm setting examples

Examples of settings for alarm usage are shown below.

Alarm setting (example)	Alarm_W ; Day								Alarm_W ; Hour		Alarm_W ; Minute
	Day setting								Hour (hexadecimal)		Minute (hexadecimal)
	WW 6	WW 5	WW 4	WW 3	WW 2	WW 1	WW 0	24-hour clock	12-hour clock	12- & 24-hour clock	
	Sat	Fri	Thu	Wed	Tue	Mon	Sun				
Every day at 00:00 AM	1	1	1	1	1	1	1	00h hours	12h hours	00h min	
Every day at 01:30 AM	1	1	1	1	1	1	1	01h hours	01h hours	30h min	
Every day at 11:59 AM	1	1	1	1	1	1	1	11h hours	11h hours	59h min	
Mon to Fri at 12:00 PM	0	1	1	1	1	1	0	12h hours	32h hours	00h min	
Sunday at 01:30 PM	0	0	0	0	0	0	1	13h hours	21h hours	30h min	
Mon/Wed/Fri at 11:59 PM	0	1	0	1	0	1	0	23h hours	31h hours	59h min	

8.5.3. WAFG, DAFG and /INT, /INT output

* See "WAFG, DAFG and /INT, /INT output" in section 8.7.2.

8.6. Alarm D function

The Alarm D function generates interrupt signals (output via the /INT pin) that correspond to specified hours and minutes.

For description of the Alarm W function, which supports only day, hour, and minute data, see "8.5. Alarm W Function".

A polling function is also provided to enable checking of each alarm mode by the host.

8.6.1. Related registers

Address	Function	bit 7	bit 6	bit 5	bit 4	bit 3	bit 2	bit 1	bit 0
1	Minutes	○	M40	M20	M10	M8	M4	M2	M1
2	Hours	○	○	H20 P, /A	H10	H8	H4	H2	H1
B	Alarm_D ; Minute	○	DM40	DM20	DM10	DM8	DM4	DM2	DM1
C	Alarm_D ; Hour	○	○	DH20 DP, /A	DH10	DH8	DH4	DH2	DH1
E	Control 1 (Default)	WALE (0)	DALE (0)	/12, 24 (0)	/CLEN2 (0)	TEST (0)	CT2 (0)	CT1 (0)	CT0 (0)
F	Control 2 (Default)	VDSL (0)	VDET (0)	/XST (-)	PON (1)	/CLEN1 (0)	CTFG (0)	WAFG (0)	DAFG (0)

*1) The default value is the value that is read (or is set internally) after the PON bit has been set to "1," such as after powering up from 0 V or recovering from a supply voltage drop.

*2) " " indicates write-protected bits. A zero is always read from these bits.

*3) "-" indicates undefined status.

- When the Alarm_D setting matches the current time, /INT pin is set to "L" and the DALE bit is set to "1".
Note: If the current date/time is used as the Alarm_D setting, the alarm will not occur until the counter counts up to the current date/time (i.e., an alarm will occur next time, not immediately).
- During 24-hour clock operation, the "Alarm_D ; Hours" register's bit 5 (DH20, DP, /A) functions as DH20 (two-digit hour display), and during 12-hour clock operation it functions as an AM/PM indicator.

1) DALE bit

This bit is used to set up the Alarm D function (to generate alarms matching hour or minute settings).

DALE	Data	Description
Write / Read	0	Alarm_D, match comparison operation invalid * Default
	1	Alarm_D, match comparison operation valid (/INT = "L" when match occurs)

* When using the Alarm D function, first set this DALE bit value as "0," then stop the function. Next, set the hour, minute, and the DAFG bit. Finally, set "1" to the DALE bit to set the Alarm D function as valid.

The reason for first setting the DALE bit value as "0" is to prevent /INT = "L" output in the event that a match between the current time and alarm setting occurs while the alarm setting is still being made.

2) DAFG bit

This bit is valid only when the DALE bit value is "1". When a match occurs between the Alarm_D setting and the current time, the DAFG bit value becomes "1" approximately 61 μs afterward. (There is no effect when the DALE bit becomes "0".)

The /INT = "L" status that is set at this time can be set to OFF by writing a "0" to this bit.

DAFG	Data	Description
Write	0	/INT pin = OFF (Hi-z) (only when periodic interrupt output is OFF) * Default
	1	Setting prohibited (do not set this bit value, even though it has no effect)
Read	0	Alarm_D time setting does not match current time (This bit's value is always "0" when the DALE bit's setting is "0") * Default
	1	Alarm_D time setting matches current time (result is that bit value is held until cleared to zero)

* When a "0" is written to the DAFG bit, provisionally the DAFG bit value is "0" and the /INT pin status is OFF (Hi-z). However, as long as the DALE bit value is "1" the Alarm D function continues to operate, and Alarm D occurs again the next time the same specified time arrives.

You can stop Alarm D from occurring by writing "0" to the DALE bit to set this function as invalid.

3) /12,24 bit

* See "/12, 24 bit" in section 8.5.1.3.

8.6.2. WAFG, DAFG and /INT, /INT output

* See "WAFG, DAFG and /INT output" in section 8.7.2.

8.7. /INT Output during Operation of Interrupt Function

8.7.1. Shared /INT output

The /INT interrupt output pin is shared as the output pin for interrupt events from three functions: the periodic interrupt function, Alarm W function, and Alarm D function. The /INT pin outputs at low level when any one of these interrupt events occurs.

When an interrupt has occurred (/INT = "L"), the CTFG, WAFG, and DAFG flags are read to determine which type of interrupt event has occurred (indicated by a "1" value in the corresponding flag).

The /INT setting must be cleared via bit manipulation when another interrupt occurs or when the same interrupt occurs again (this sets /INT to high impedance).

8.7.2. WAFG, DAFG, and /INT output

The following illustrates how the WAFG and DAFG bits relate to /INT output with regard to the operation of the Alarm W function and Alarm D function.

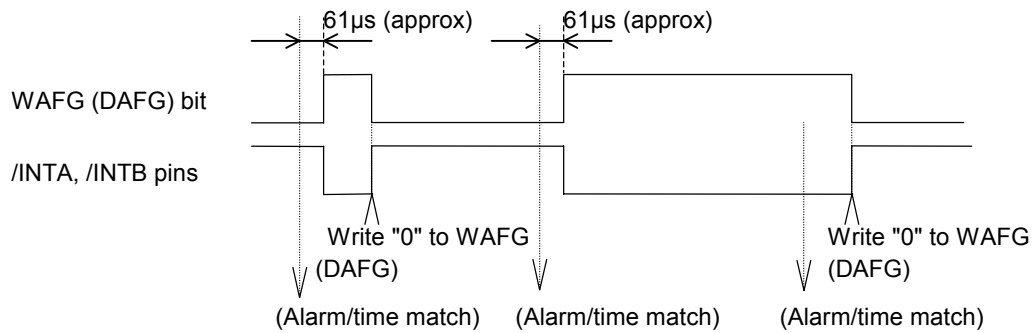

8.8. The various detection Functions

The detection functions include detection of power-on resets, oscillation stops, and supply voltage drops, as well as reporting of detection results in corresponding bits of the address Fh (Control 2) register. The status of the power supply, oscillation circuit, and clock can be confirmed by checking these results.

* Note with caution that detection functions may not operate correctly when power flickers occur.

8.8.1. Related register

Address	Function	bit 7	bit 6	bit 5	bit 4	bit 3	bit 2	bit 1	bit 0
F	Control 2 (Default)	VDSL (0)	VDET (0)	/XST (-)	PON (1)	/CLEN1 (0)	CTFG (0)	WAFG (0)	DAFG (0)

*1) The default value is the value that is read (or is set internally) after the PON bit has been set to "1," such as after powering up from 0 V or recovering from a supply voltage drop.

*2) "-" indicates undefined status.

8.8.1. Power-on reset detection

This function detects when a power-on reset occurs. When a power-on reset is detected, the PON bit value becomes "1".

A reset is detected when a power-on from 0 V has occurred, including when the power-on reset from 0 V occurred due to a supply voltage drop.

1) PON bit

This bit indicates the detection results when a power-on reset has occurred.

The power-on reset function operates when a power-on from 0 V has occurred, including when a power-on reset from 0 V occurred due to a supply voltage drop. When this function operates, the PON bit value becomes "1".

The /XST and VDET bits can be used in combination to determine the valid/invalid status of the clock and calendar data.

PON	Data	Description
Write	0	Clears PON bit to zero and sets up for next detection operation
	1	Setting prohibited (do not set this bit value, even though it has no effect)
Read	0	Power-on reset was not detected
	1	Power-on reset was detected (result is that bit value is held until cleared to zero) * Default

* When PON = "1" the clock precision adjustment register, Control register 1, and Control register 2 (except for PON and /XST) are reset and cleared to "0". This stops (sets Hi-Z for) output from the /INT and /INT pins.

2) Status of other bits when power-on reset is detected

- Internal initialization status during a power-on reset

Address	Function	bit 7	bit 6	bit 5	bit 4	bit 3	bit 2	bit 1	bit 0
7	Digital Offset (Default)	0 (0)	F6 (0)	F5 (0)	F4 (0)	F3 (0)	F2 (0)	F1 (0)	F0 (0)
E	Control 1 (Default)	WALE (0)	DALE (0)	/12, 24 (0)	/CLEN2 (0)	TEST (0)	CT2 (0)	CT1 (0)	CT0 (0)
F	Control 2 (Default)	VDSL (0)	VDET (0)	/XST (-)	PON (1)	/CLEN1 (0)	CTFG (0)	WAFG (0)	DAFG (0)

*1) The default value is the value that is read (or is set internally) after the PON bit has been set to "1," such as after powering up from 0 V or recovering from a supply voltage drop.

*2) "-" indicates undefined status.

*3) At this point, all other register bits are undefined, so be sure to perform a reset before using the module. Also, be sure to avoid entering incorrect date and time data, as clock operations are not guaranteed when the time data is incorrect.

8.8.2. Oscillation stop detection

This function detects when internal oscillation has stopped. When an oscillation stop is detected, the /XST bit value becomes "0".

If a "1" has already been written to the /XST bit, the /XST bit is cleared to zero when stopping of internal oscillation is detected, so this function can be used to determine whether or not an oscillation stop has occurred previously, such as after recovery from a backup.

1) /XST bit

This bit indicates the oscillation stop detection function's detection results.

/XST	Data	Description
Write	0	Setting prohibited (do not set this bit value, even though it has no effect)
	1	Sets the oscillation stop detection function as use-enabled and sets up for next detection operation
Read	0	Oscillation stop was detected (result is that bit value is held until a "1" is written)
	1	Oscillation stop was not detected

2) Caution points

To prevent detection errors during operation of the oscillation stop detection function, be sure to prevent stops due to VDD power flicker and prevent application of voltage exceeding the maximum rated voltage to any pin. In particular, fluctuation in the supply voltage may occur as shown in the figure at right, such as when a back-up battery is used. If this occurs, internal data may be lost even when the /XST bit value has not changed from "1" to "0" so be sure to avoid any input that contains large amounts of chattering.

Example of voltage fluctuation that makes oscillation stop hard to detect



8.8.3. Voltage drop detection

This function detects when a voltage drop occurs. Detection of a voltage drop changes the VDET bit value to "1". The threshold voltage value for detection can be set via the VDSL bit as 2.1 V or 1.3 V.

1) VDSL bit

This bit is used to set the power drop detection function's threshold voltage value.

VDSL	Data	Description
Write / Read	0	Sets 2.1 V as the power drop detection function's threshold voltage value * Default
	1	Sets 1.3 V as the power drop detection function's threshold voltage value

2) VDET bit

This bit indicates the power drop detection function's detection results. VDET = "1" once a power voltage drop has occurred. This detection operation is then stopped and the bit value (1) is held.

VDET	Data	Description
Write	0	Clears the VDET bit to zero, restarts the power drop detection operation and sets up for next power drop detection operation * Default
	1	Setting prohibited (do not set this bit value, even though it has no effect)
Read	0	Power drop was not detected * Default
	1	Power drop was detected (result is that bit value is held until cleared to zero)

3) Caution points

To reduce current consumption while monitoring the supply voltage, the supply voltage monitor circuit samples for only 7.8 ms during each second, as shown at right. Sampling is stopped once the VDET bit = "1". (Clear the VDET bit to zero to resume operation of the detection function.)

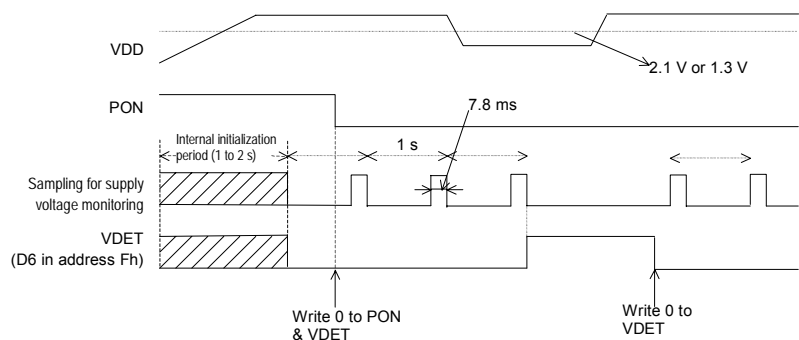

8.8.4. Estimation of status based on detection results

The power supply status and clock status can be confirmed by reading the detection results indicated by the PON, /XST, and VDET bits.

The following are status estimates based on various combinations of detection results.

Address F h Control 2 Register			Estimated status	
bit 4	bit 5	bit 6	Status of power supply and oscillation circuit	Status of clock and backup
PON	/XST	VDET		
0	0	0	• No supply voltage drop, but oscillation has stopped.	• Clock abnormality has occurred → Initialization is required * Clock has stopped temporarily, possibly due to condensation.
0	0	1	• Supply voltage has dropped and oscillation has stopped.	• Clock abnormality has occurred → Initialization is required * Clock has stopped, perhaps due to drop in backup power supply.
0	1	0	• Normal status.	• Normal status.
0	1	1	• Supply voltage has dropped but oscillation continues.	• Clock is normal, but an abnormality exists in the power supply. * Backup power supply may have dropped to a hazardous level.
1	0	x	• Supply voltage has dropped to 0 V.	• Initialization is required regardless of the clock status and whether or not a voltage drop has occurred. * Initialization is required due to bits that are reset when PON = "1".
1	1	x	• Power supply flickering is likely.	

* The example shown above is when a "1" has already been written to /XST.

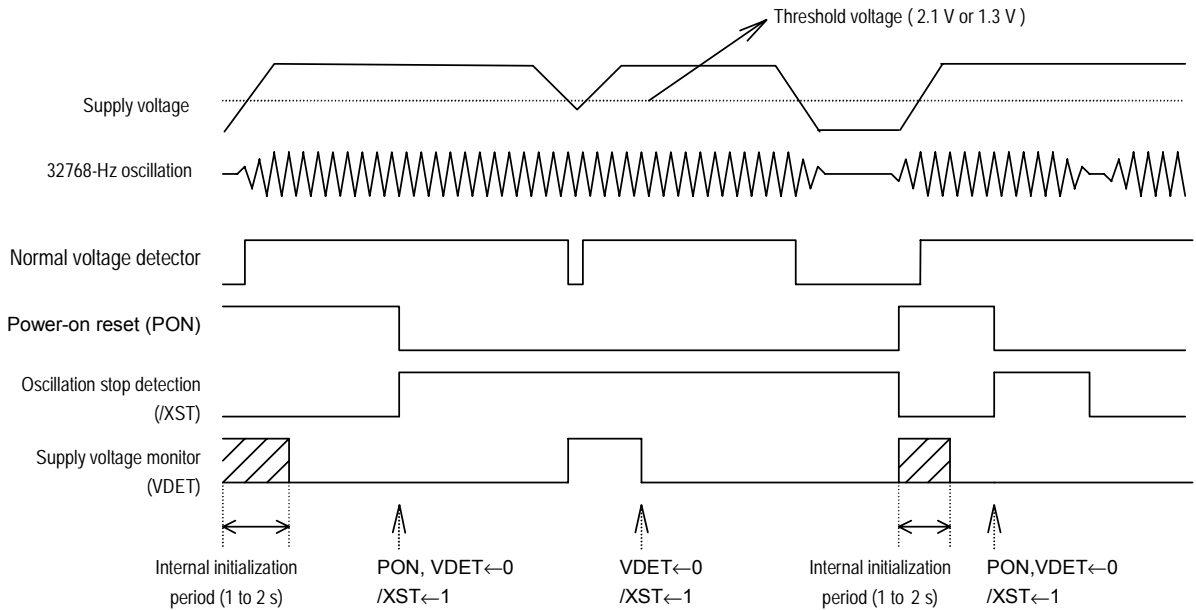

8.9. Read/Write of Data

8.9.1. Data transfer method

1) CE and data capture timing

The RX-4045 uses a four-line serial interface to transfer data across four pins: CE (chip enable), CLK (serial clock), DI (data input), and DO (data output).

For data transfers, select between two methods for clock timing of the DI and DO signals: "capture at falling edge and output at rising edge" or "capture at rising edge and output at falling edge".

(1) Capture data at falling edge and output at rising edge

When the CE signal goes from low to high, if CLK is low, the data is captured at the falling edge and output at the rising edge.

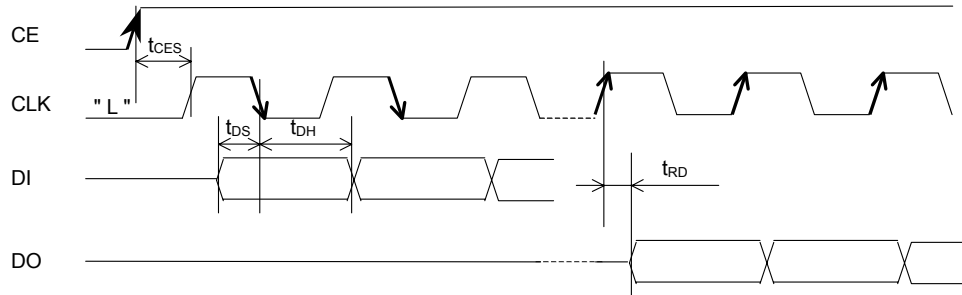

(2) Capture data at rising edge and output at falling edge

When the CE goes from low to high, if CLK is H, the data is captured at the rising edge and output at the falling edge.

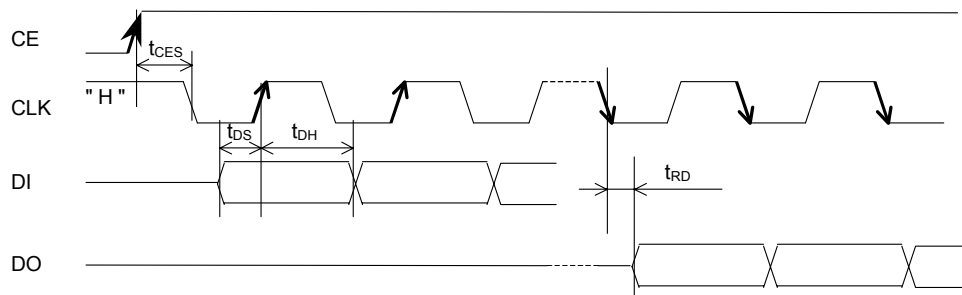

2) Data transfer format

Data transfer starts at the rising edge and ends at the falling edge of CE input.

Each byte (8 bits) is handled as a unit, and any number of bytes can be transferred consecutively.

The start address for starting transfer from the host is specified (as an address pointer setting) in the first four bits of the first byte. A transfer format register setting in the second four bits determines whether data will be written or read and which transfer format will be used.

All transfers are performed in MSB-first order.

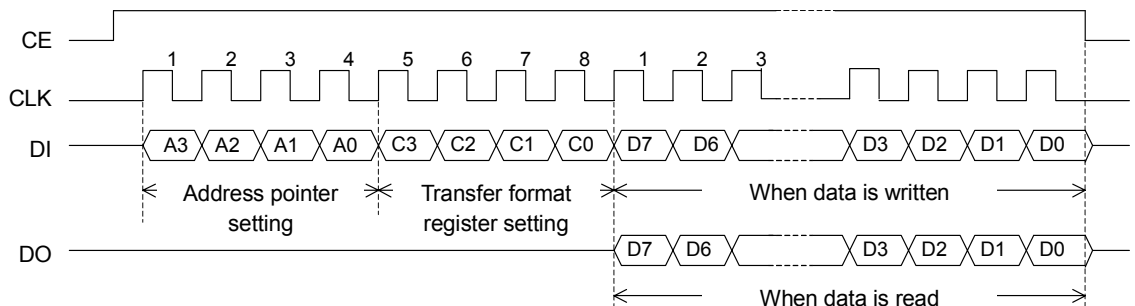

* There are two transfer methods each for read and write operations.

8.9.2. Write methods for data transfer

1) Single-byte write method

The first data write method transfers each byte of data independently.

The target address for writing is specified by the address pointer and "8h" is written to the transfer format register.

After one byte of data has been transferred, the transfer can be terminated by setting the CE pin to low level, or the transfer operation can be continued by specifying a new target address and transfer format.

Example of data write (to addresses Fh and 7h)

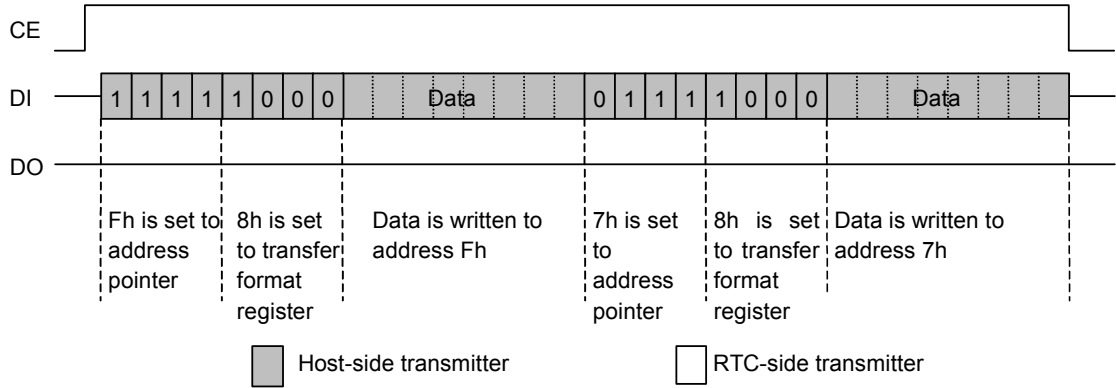

2) Burst write method

The second data write method transfers data consecutively.

The target address for writing is specified by the address pointer and "0h" is written to the transfer format register.

The address pointer is incremented each time a byte is transferred. The next address pointer value after Fh is 0h.

Lastly, the transfer is terminated by setting the CE pin to low level.

Example of data write (to addresses Eh, Fh, and 0h)

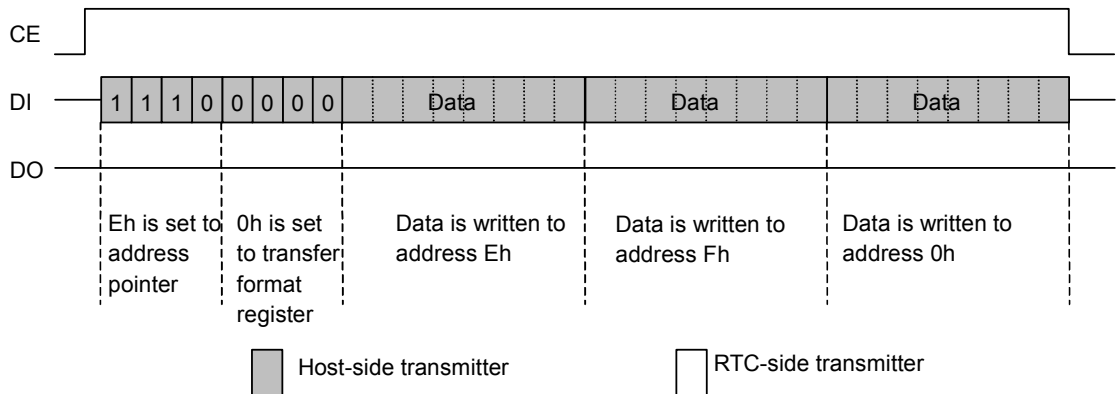

8.9.3. Read methods for data transfer

1) Single-byte read method

The first data read method transfers each byte of data independently.

The target address for reading is specified by the address pointer and "Ch" is written to the transfer format register.

After one byte of data has been transferred, the transfer can be terminated by setting the CE pin to low level, or the transfer operation can be continued by specifying a new target address and transfer format.

Example of data read (from addresses Eh and 2h)

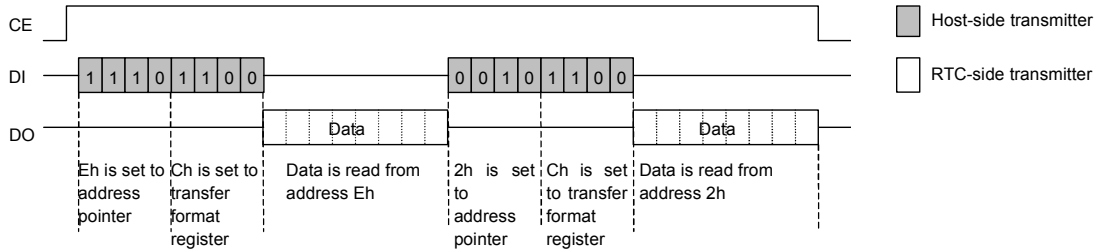

2) Burst read method

The second data read method transfers data consecutively.

The target address for writing is specified by the address pointer and "4h" is written to the transfer format register. The address pointer is incremented each time a byte is transferred.

The next address pointer value after Fh is 0h.

Lastly, the transfer is terminated by setting the CE pin to low level.

Example of data read (from addresses Fh, 0h, and 1h)

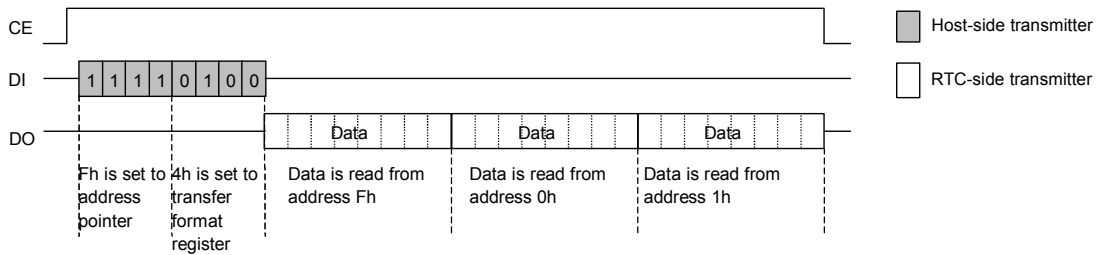

3) Consecutive read and consecutive write

After reading one byte or writing one byte, this method enables another transfer to be performed consecutively.

Example of consecutive data read/write (reading and writing of data at address Fh)

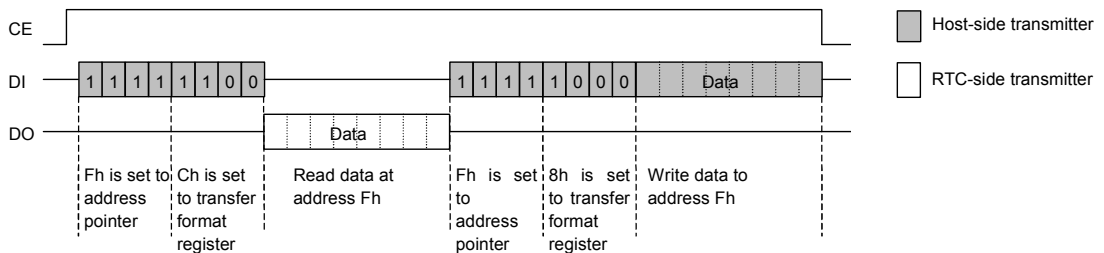

* The following table provides a summary of the relation between the read/write format and settings in the transfer format register.

	Single byte	Burst (consecutive)
Write to RTC	8h (1,0,0,0)	0h (0,0,0,0)
Read from RTC	Ch (1,1,0,0)	4h (0,1,0,0)

8.9.4. Caution points on read/write of time data

If the time value is changed across several digits during a time read/write operation, an incorrect time value may be read or written.

For example, if a read operation is started when the time value is 13:59:59 and the timer's value changes from 13:59:59 to 14:00:00 while the time value is being read (sequentially from seconds to minutes to hours), the read values for "seconds" and "minutes" may be each "59" while the read value for "hours" may be "14", resulting in a read time value of 14:59:59, which is off by one hour. Similar errors can occur when writing time values.

The RX-4045 prevents these types of read/write errors by setting the time value incrementation function on hold while the CE pin is at high level (the hold is canceled and incrementation resumes when the CE pin returns to low level).

Since the hold function operates only for one second, the CE pin must return to low level within one second.

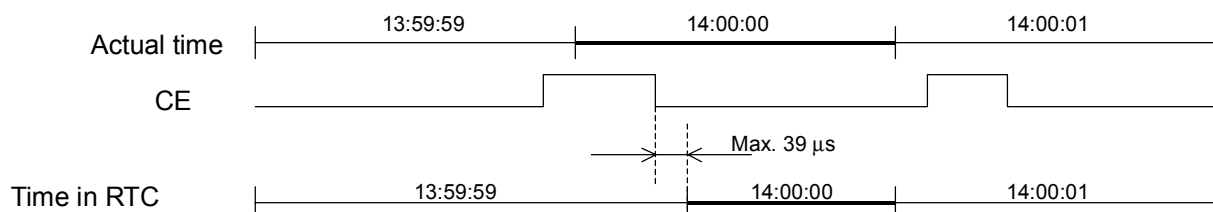

Note the following caution points when using this function while reading or writing time values.

- (1) Keep the CE pin at high level while reading or writing one time value.
- (2) The period during which CE = H should not exceed one second. Due to the remote possibility that the host system may go down while reading or writing a time value, a peripheral circuit should be implemented to set CE as either low or open as soon as such an event occurs.
- (3) After CE has been switched from low to high, leave a time interval of at least 31 μs before accessing any address from 0h to 6h. (This allows time for completion of any incrementation of two digits or more in the time value that the RX-4045 might be performing.)
- (4) After CE has been switched from high to low, leave a time interval of at least 61 μs before CE is switched high again. (This allows the RX-4045 to correct the time value if the value was due to change while CE = H.)
- (5) The above caution points do not have to be considered as long as time read/write operations are clearly set so as to avoid time value incrementation of two or more digits (such as by timing the read/write operation to coincide with level-mode periodic interrupts or alarm interrupts.)

* Correct and incorrect examples of time read/write operations are illustrated on the next page.

Correct example

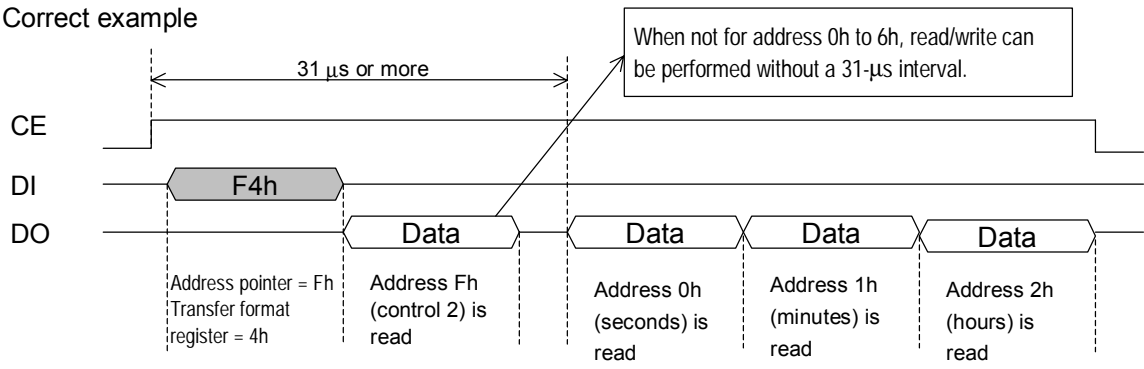

Incorrect example 1: CE is set low once while reading the time value.

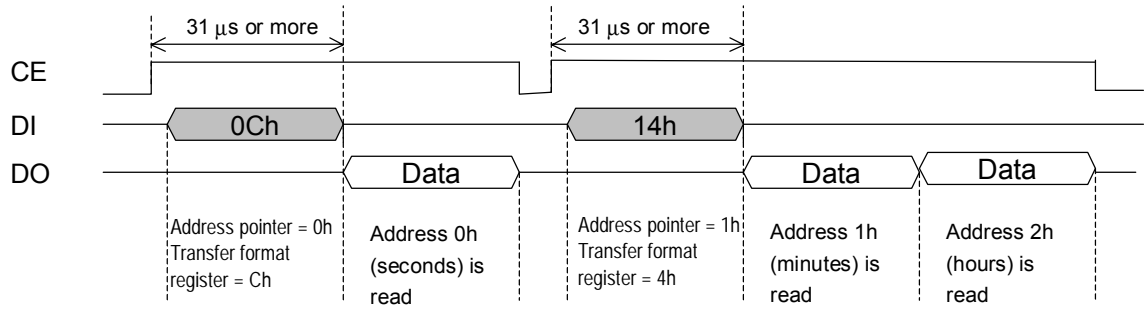

Incorrect example 2: If interval is less than 31 μs when time write operation is started

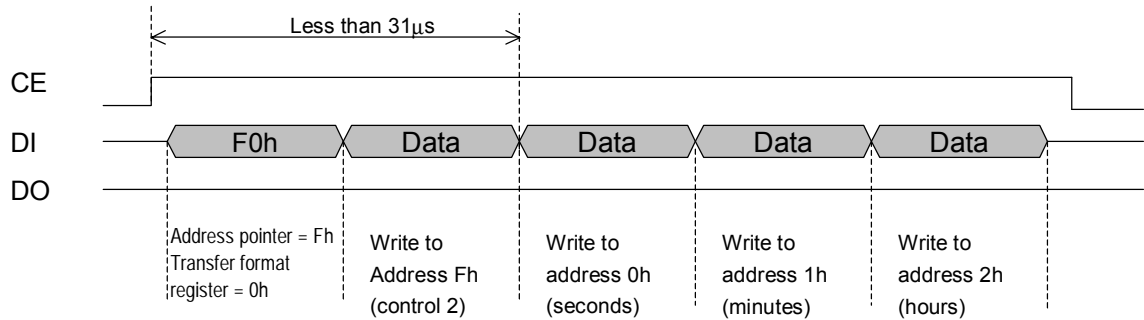

Incorrect example 3: If interval between two time read operations is less than 61 μs

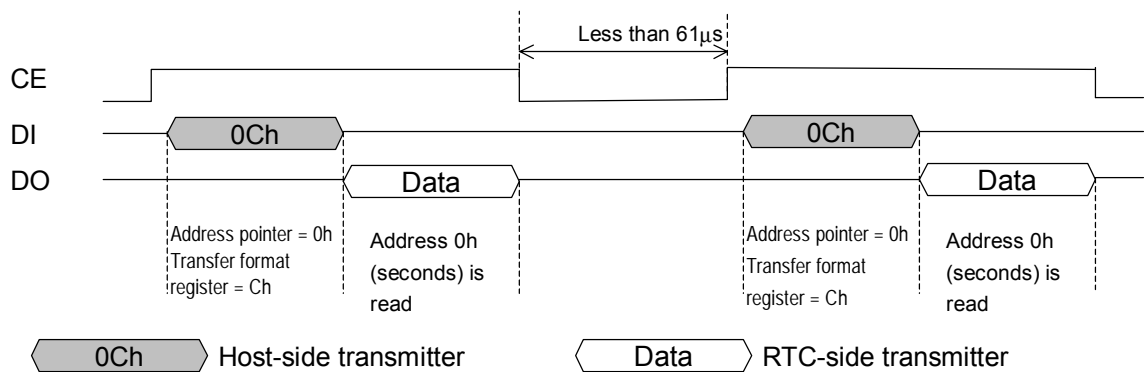

8.10. External Connection Example

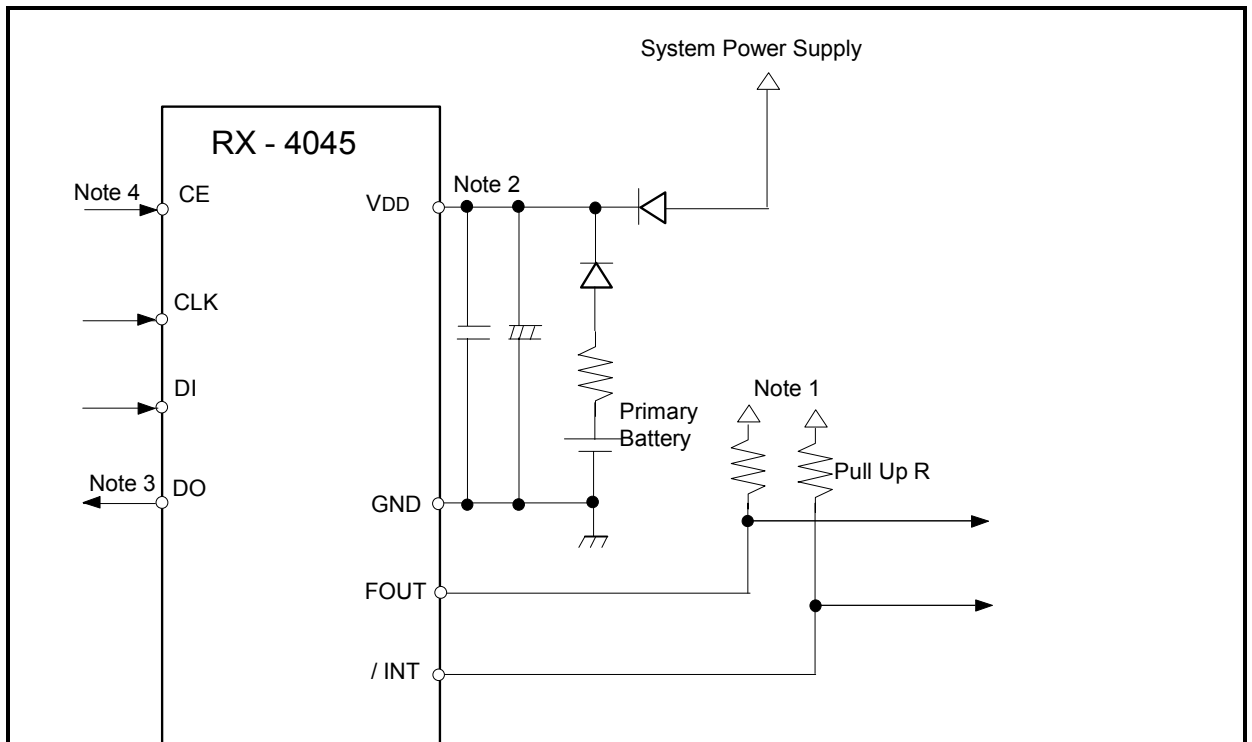

Note 1

FOUT and INT terminal is Nch-Open Drain output, and the protective diode doesn't exist in Vdd side. Therefore pull up is possible to 5.5 V without relation of the power supply voltage of this device. Pull up resistor is connected to system power supply when doesn't use the output signal in backup. Pull up resistor is connected to backup power supply when using the output signal in backup. In case of both, be careful with a current of resistor.

Note 2

RTC module recommends that you installs the two capacitors for low frequency and high frequency in closest to the RTC.

Note 3

Maintain the voltage of DO terminal lower than $VDD + 0.3 V$ which is maximum rating absolutely when supply a power supply of this device with diode OR.

Note 4

Warn the following points, about connection of CE-terminal.

When a power supply voltage rises from 0 V or the host side power is downed, CE = L or open.

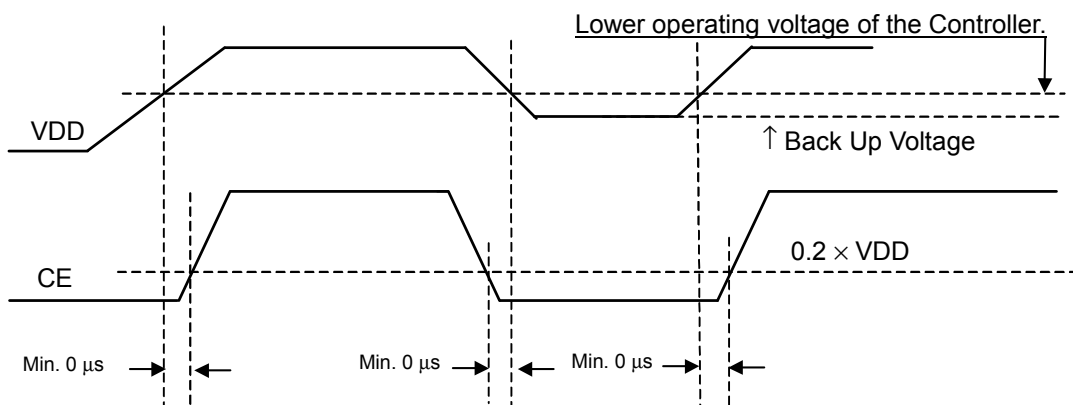

9. External Dimensions / Marking Layout

9.1. External Dimensions

RX-4045 SA (SOP-14pin)

• External dimensions

• Recommended soldering

Unit : mm

* The cylinder of the crystal oscillator can be seen in this area (back and front), but it has no affect on the performance of the device.

RX-4045 NB (SON-22pin)

• External dimensions

* In this area(), pattern layout is not allowed.

Unit : mm

• Soldering pattern

*2) Pattern (GND, power line, signal line, soldering pattern etc) is not allowed.

*3) GND pattern recommended area

*1) The cylinder of the crystal oscillator may be exposed in this area (top and bottom), however it has no affect on the performance of the device.

*2) Pattern (GND, power line, signal line, soldering pattern, etc) is not allowed. In this area, at a parts side of board, do not pattern layout surely.

* In an area () of the product bottom side, a terminal connected to an IC inside is exposed. When the circuit pattern contacts those terminal, it will cause serious obstruction to the oscillation, function or electronic spec.

*3) It is the best design that there is no signal line in this area. Please fill it up with GND pattern if possible.

9.2. Marking Layout

RX - 4045 SA (SOP-14pin)

RX - 4045 NB (SON-22pin)

* The layout shown above is a simplified drawing of the seal and label. Details such as the fonts, sizes, and positioning of label contents are not necessarily as shown.

10. Reference Data

(1) Example of frequency and temperature characteristics

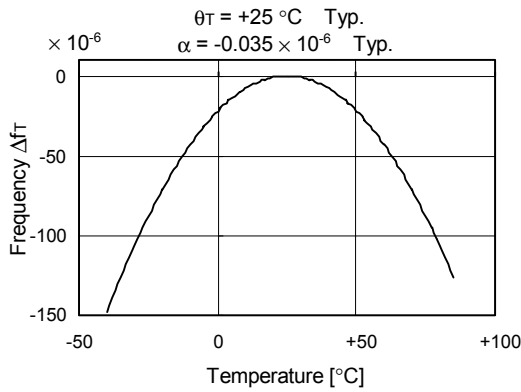

[Finding the frequency stability]

1. Frequency and temperature characteristics can be approximated using the following equations.

$$\Delta f_T = \alpha (\theta_T - \theta_X)^2$$

Δf_T Frequency deviation in any temperature

α ($1 / \text{ }^\circ\text{C}^2$) Coefficient of secondary temperature
 $(-0.035 \pm 0.005) \times 10^{-6} / \text{ }^\circ\text{C}^2$

θ_T ($^\circ\text{C}$) Ultimate temperature (+25±5 °C)

θ_X ($^\circ\text{C}$) Any temperature

2. To determine overall clock accuracy, add the frequency precision and voltage characteristics.

$$\Delta f/f = \Delta f/f_0 + \Delta f_T + \Delta f_V$$

$\Delta f/f$ Clock accuracy (stable frequency) in any temperature and voltage

$\Delta f/f_0$ Frequency precision

Δf_T Frequency deviation in any temperature

Δf_V Frequency deviation in any voltage

(2) Example of frequency and voltage characteristics

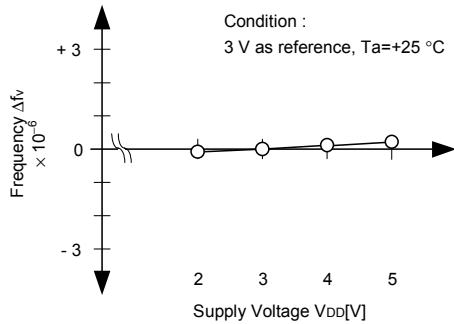

3. How to find the date difference

$$\text{Date difference} = \Delta f/f \times 86400 \text{ (seconds)}$$

* For example: $\Delta f/f = 11.574 \times 10^{-6}$ is an error of approximately 1 second/day.

(3) Current and voltage consumption characteristics

Current consumption when non-accessed (i)
when FOUT=OFF

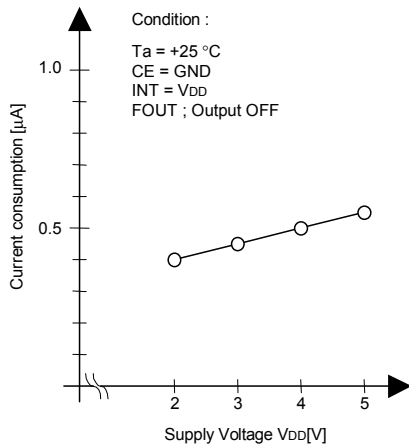

11. Application notes

1) Notes on handling

This module uses a C-MOS IC to realize low power consumption. Carefully note the following cautions when handling.

(1) Static electricity

While this module has built-in circuitry designed to protect it against electrostatic discharge, the chip could still be damaged by a large discharge of static electricity. Containers used for packing and transport should be constructed of conductive materials. In addition, only soldering irons, measurement circuits, and other such devices which do not leak high voltage should be used with this module, which should also be grounded when such devices are being used.

(2) Noise

If a signal with excessive external noise is applied to the power supply or input pins, the device may malfunction or "latch up." In order to ensure stable operation, connect a filter capacitor (preferably ceramic) of greater than 0.1F as close as possible to the power supply pins (between VDD and GNDs). Also, avoid placing any device that generates high level of electronic noise near this module.

* Do not connect signal lines to the shaded area in the figure shown in Fig. 1 and, if possible, embed this area in a GND land.

(3) Voltage levels of input pins

When the input pins are at the mid-level, this will cause increased current consumption and a reduced noise margin, and can impair the functioning of the device. Therefore, try as much as possible to apply the voltage level close to VDD or GND.

(4) Handling of unused pins

Since the input impedance of the input pins is extremely high, operating the device with these pins in the open circuit state can lead to unstable voltage level and malfunctions due to noise. Therefore, pull-up or pull-down resistors should be provided for all unused input pins.

2) Notes on packaging

(1) Soldering heat resistance.

If the temperature within the package exceeds +260 °C, the characteristics of the crystal oscillator will be degraded and it may be damaged. The reflow conditions within our reflow profile is recommended. Therefore, always check the mounting temperature and time before mounting this device. Also, check again if the mounting conditions are later changed.

* See Fig. 2 profile for our evaluation of Soldering heat resistance for reference.

(2) Mounting equipment

While this module can be used with general-purpose mounting equipment, the internal crystal oscillator may be damaged in some circumstances, depending on the equipment and conditions. Therefore, be sure to check this. In addition, if the mounting conditions are later changed, the same check should be performed again.

(3) Ultrasonic cleaning

Depending on the usage conditions, there is a possibility that the crystal oscillator will be damaged by resonance during ultrasonic cleaning. Since the conditions under which ultrasonic cleaning is carried out (the type of cleaner, power level, time state of the inside of the cleaning vessel, etc.) vary widely, this device is not warranted against damage during ultrasonic cleaning.

(4) Mounting orientation

This device can be damaged if it is mounted in the wrong orientation. Always confirm the orientation of the device before mounting.

(5) Leakage between pins

Leakage between pins may occur if the power is turned on while the device has condensation or dirt on it. Make sure the device is dry and clean before supplying power to it.

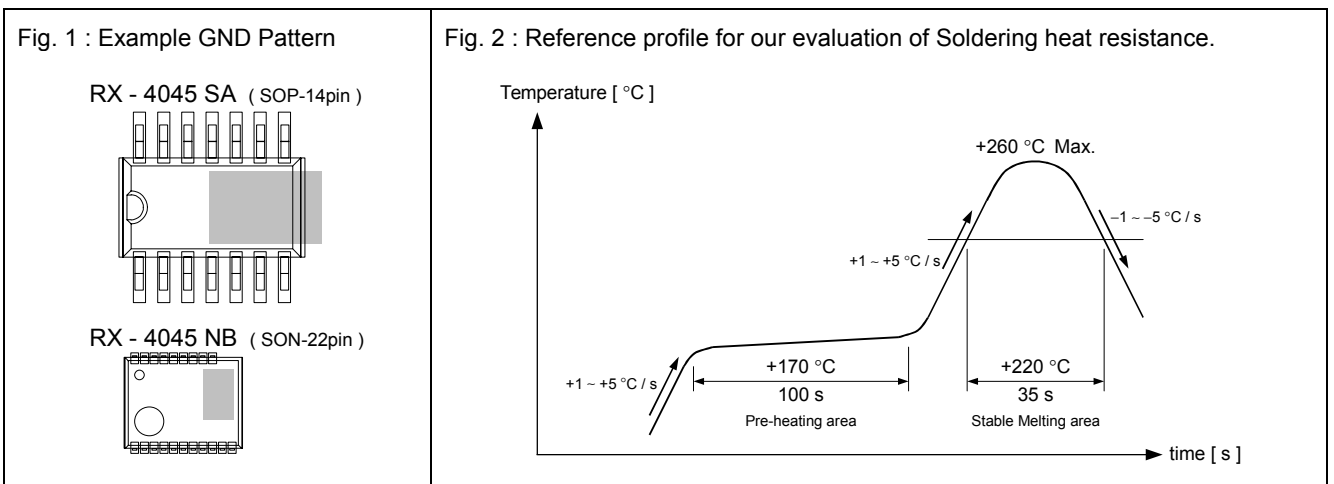

In addition, please confirm the Notes of an individual specification.

Application Manual

AMERICA

EPSON ELECTRONICS AMERICA, INC.

HEADQUARTER	150 River Oaks Parkway, San Jose, CA 95134, U.S.A. Phone: (1)800-228-3964 (Toll free) : (1)408-922-0200 (Main) Fax: (1)408-922-0238 http://www.eea.epson.com
Atlanta Office	One Crown Center 1895 Phoenix Blvd. Suite 348 Atlanta, GA 30349 Phone: (1)800-228-3964 (Toll free) : (1)770-907-7667 (Main)
Boston Office	301 Edgewater Place, Ste. 120, Wakefield, MA 01880, U.S.A. Phone: (1)800-922-7667 (Toll free) : (1)781-246-3600 (Main) Fax: (1)781-246-5443
Chicago Office	101 Virginia St., Ste. 290, Crystal Lake, IL 60014, U.S.A. Phone: (1)800-853-3588 (Toll free) : (1)815-455-7630 (Main) Fax: (1)815-455-7633
El Segundo Office	1960 E. Grand Ave., 2nd Floor, El Segundo, CA 90245, U.S.A. Phone: (1)800-249-7730 (Toll free) : (1)310-955-5300 (Main) Fax: (1)310-955-5400

EUROPE

EPSON EUROPE ELECTRONICS GmbH

HEADQUARTER	Riesstrasse 15, 80992 Munich, Germany Phone: (49)-(0)89-14005-0 Fax: (49)-(0)89-14005-110 http://www.epson-electronics.de
Düsseldorf Branch Office	Altstadtstrasse 176, 51379 Leverkusen, Germany Phone: (49)-(0)2171-5045-0 Fax: (49)-(0)2171-5045-10
UK & Ireland Branch Office	Unit 2.4, Doncastle House, Doncastle Road, Bracknell, Berkshire RG12 8PE, England Phone: (44)-(0)1344-381700 Fax: (44)-(0)1344-381701
French Branch Office	LP 915 Les Conquérants, 1 Avenue de l' Atlantique, Z.A. de Courtaboeuf 2 91976 Les Ulis Cedex, France Phone: (33)-(0)1-64862350 Fax: (33)-(0)1-64862355

ASIA

EPSON (CHINA) CO., LTD.

23F, Beijing Silver Tower 2# North RD DongSangHuan ChaoYang District, Beijing, China
Phone: (86) 10-6410-6655 Fax: (86) 10-6410-7319
<http://www.epson.com.cn>

Shanghai Branch	High-Tech Building, 900 Yishan Road Shanghai 200233, China Phone: (86) 21-5423-5577 Fax: (86) 21-5423-4677
------------------------	---

EPSON HONG KONG LTD.

20/F., Harbour Centre, 25 Harbour Road, Wanchai, Hong Kong
Phone: (852) 2585-4600 Fax: (852) 2827-2152
<http://www.epson.com.hk>

EPSON ELECTRONIC TECHNOLOGY DEVELOPMENT (SHENZHEN) CO., LTD.

12/F, Dawning Mansion, #12 Keji South Road, Hi-Tech Park, Shenzhen, China
Phone: (86) 755-26993828 Fax: (86) 755-26993838

EPSON TAIWAN TECHNOLOGY & TRADING LTD.

14F, No.7, Song Ren Road, Taipei 110
Phone: (886) 2-8786-6688 Fax: (886) 2-8786-6660
<http://www.epson.com.tw>

EPSON SINGAPORE PTE. LTD.

No 1 HarbourFront Place, #03-02 HarbourFront Tower One, Singapore 098633.
Tel: (65)- 6-586-5500 Fax: (65) 6-271-3182
<http://www.epson.com.sg>

SEIKO EPSON CORPORATION KOREA Office

50F, KLI 63 Building, 60 Yoido-dong, Youngdeungpo-Ku, Seoul, 150-763, Korea
Phone: (82) 2-784-6027 Fax: (82) 2-767-3677
<http://www.epson-device.co.kr>

Gumi Branch Office	2F, Grand Bldg, 457-4, Songjeong-dong Gumi-City, Gyongsangbuk-Do, 730-090, Korea Phone: (82) 54-454-6027 Fax: (82) 54-454-6093
---------------------------	--